

R5 RA 0155 A

Oil-lubricated rotary vane vacuum pump



VACUUM SOLUTIONS



Reliable

Robust construction, highly durable fiber-reinforced epoxy resin vanes, proven rotary vane technology, long service life

High performance

High pumping speed at low pressures, designed for continuous operation in the rough vacuum range

Flexible

Easy adaption to individual customer requirements and processes, level and temperature switch as standard

Accessories

- Gas-ballast valve
- Various inlet filters
- Adapter flange for vacuum booster
- Filter pressure gauge
- Vacuum pump oils for all applications
- Oil level switch
- Temperature sensors
- Starter unit
- Oxygen version

R5 RA 0155 A

Oil-lubricated rotary vane vacuum pump



VACUUM SOLUTIONS

Dimensional drawing

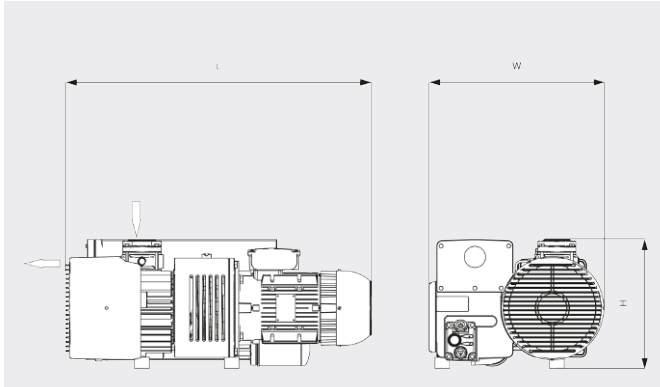

Pumping speed

Air at 20°C. Tolerance: ± 10%

— 50 Hz 60 Hz

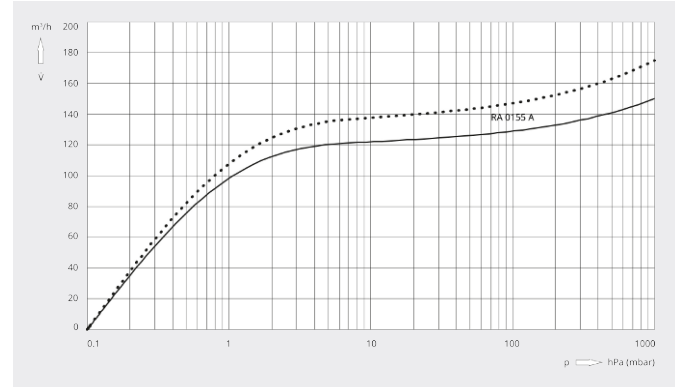

R5 RA 0155 A	
Nominal pumping speed	150 / 175 m³/h (50 / 60 Hz)
Ultimate pressure	0.1 hPa (mbar) (50 / 60 Hz)
Nominal motor rating	4.0 / 4.2 kW (50 / 60 Hz)
Nominal motor speed	1500 / 1800 min ⁻¹ (50 / 60 Hz)
Power consumption at 100 mbar	3.2 / 3.8 kW (50 / 60 Hz)
Power consumption at ultimate pressure	2.1 / 2.5 kW (50 / 60 Hz)
Noise level (ISO 2151)	70 / 72 dB(A) (50 / 60 Hz)
Oil capacity	3.5 l
Weight approx.	110 kg
Dimensions (L x W x H)	765 x 470 x 340 mm
Gas inlet / outlet	G 2" / G 2"

DO YOU WANT TO KNOW MORE?

Get in touch with us directly!
sales@busch.co.za or +27 (0)11 856 0650



CONTACT FORM



CALL NOW