

# DOLPHIN LR 1560/2200 A

Liquid ring vacuum pumps



VACUUM SOLUTIONS



## Robust

Proven technology, reliable operation, extremely high vapor and particle tolerance, specially designed for challenging environments like mining, power plants, sugar production, pulp and paper industry, steel production etc.

## High performance

High-capacity, high pumping speeds

## Flexible

Modular design, choice of cast iron (EN-GJL-200) housing with ductile cast iron impeller or all 304 grade, or 316L grade corrosion-free stainless steel material, operating fluids other than water possible, operation as compressor possible

### Accessories

- Motorized pumpsets, with gearbox or V-belt drive system, mounted on sturdy steel base frames
- Partial or total recirculation systems
- Cavitation protection
- Gas ejector
- Non-return valves
- Vacuum relief valves

# DOLPHIN LR 1560/2200 A

Liquid ring vacuum pumps



VACUUM SOLUTIONS

Dimensional drawing

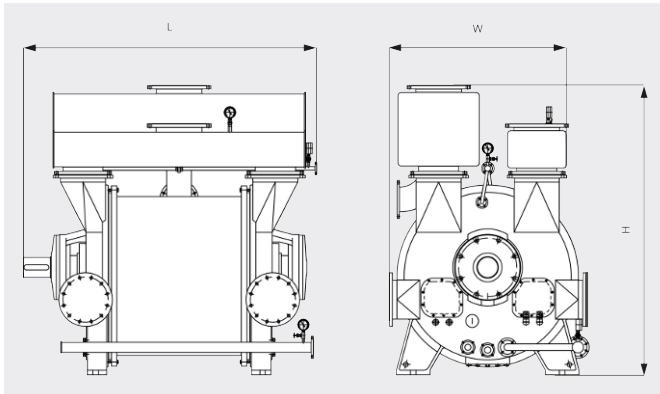

Pumping speed

Air at 20°C. Tolerance: ± 10%

— 50 Hz ..... 60 Hz

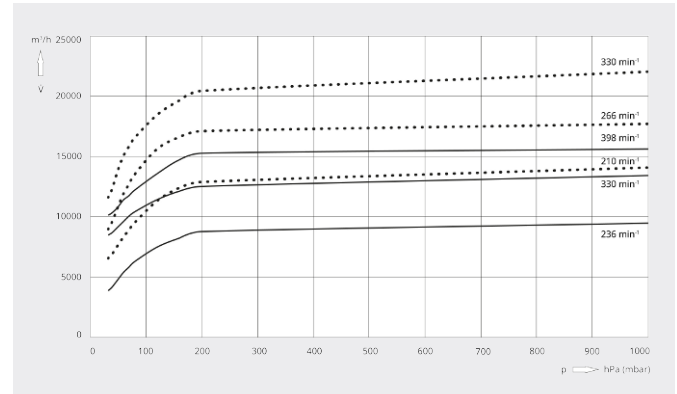

	DOLPHIN LR 1560 A	DOLPHIN LR 2200 A
Nominal pumping speed	9500 – 15600 m <sup>3</sup> /h	14100 – 22000 m <sup>3</sup> /h
Ultimate pressure	33 hPa (mbar)	33hPa (mbar)
Nominal motor rating	220 – 450 kW	355 – 600 kW
Nominal motor speed	236 – 398 min <sup>-1</sup>	210 – 330 min <sup>-1</sup>
Noise level (ISO 2151)	< 85 dB(A)	< 85 dB(A)
Weight approx.	8340 kg	12000 kg
Dimensions (L x W x H)	2512 x 1785 x 2560 mm	2891 x 2065 x 2965 mm
Gas inlet / outlet	DN 400 PN 10 / DN 400 PN 10	DN 500 PN 10 / DN 500 PN 10

DO YOU WANT TO KNOW MORE?

Get in touch with us directly!  
[sales@busch.co.za](mailto:sales@busch.co.za) or +27 (0)11 856 0650



CONTACT FORM



CALL NOW