

DOLPHIN LX 0110-0180 C

Liquid ring vacuum pumps

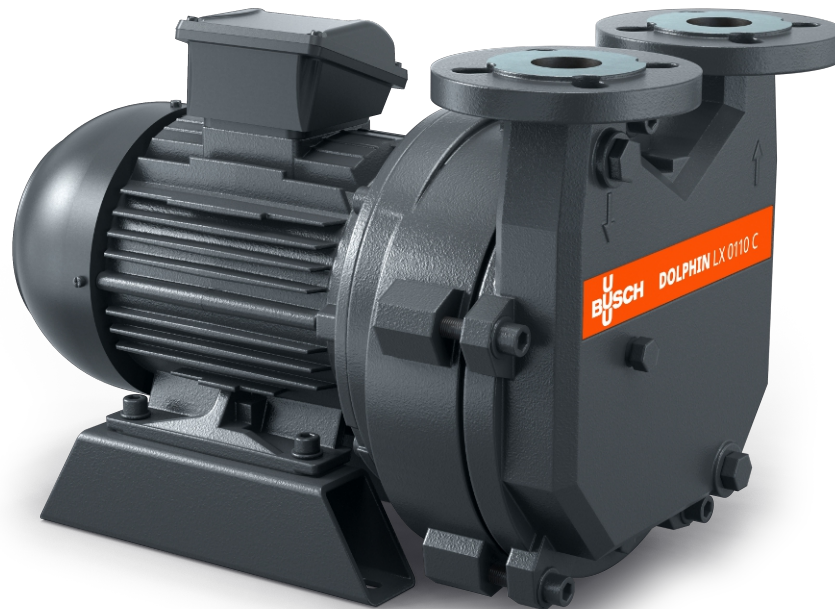

Robust

Proven technology, reliable operation, extremely high particle and vapor tolerance, corrosion-free stainless steel impeller

Compact

Directly flanged motor, no base frame required

Flexible

Choice of cast iron (EN-GJL-200) or 316 grade stainless steel material housings, ATEX-certified version available (Cat. 2 (i) IIB, T4), operating fluids other than water possible

Accessories

- Partial or total recirculation systems
- Liquid separator
- Cavitation protection
- Heat exchanger
- Gas ejector
- Wide selection of motors
- Non-return valves
- Vacuum relief valves
- Different operating fluids possible

DOLPHIN LX 0110-0180 C

Liquid ring vacuum pumps



VACUUM SOLUTIONS

Dimensional drawing

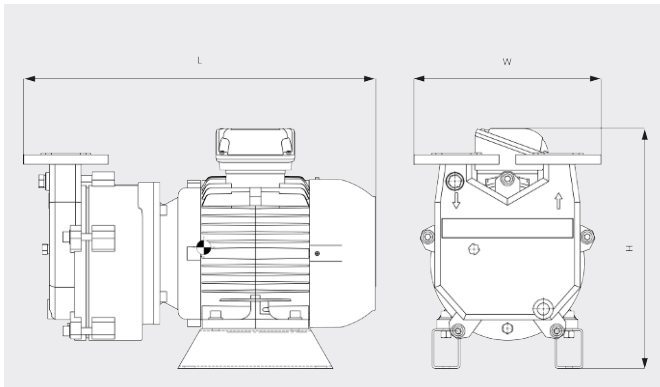

Pumping speed

Dry air at 20 °C. Operating fluid water 15 °C. Tolerance: - 10%, in accordance with HEI and Pneurop 6612

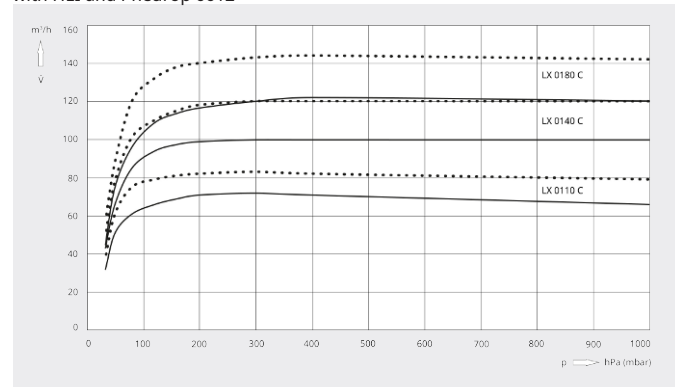

	DOLPHIN LX 0110 C	DOLPHIN LX 0140 C	DOLPHIN LX 0180 C
Nominal pumping speed	72 / 83 m³/h (50 / 60 Hz)	100 / 120 m³/h (50 / 60 Hz)	122 / 144 m³/h (50 / 60 Hz)
Ultimate pressure	33 hPa (mbar) (50 / 60 Hz)	33 hPa (mbar) (50 / 60 Hz)	33 hPa (mbar) (50 / 60 Hz)
Nominal motor rating	2.2 / 3.0 kW (50 / 60 Hz)	3.0 / 4.0 kW (50 / 60 Hz)	4.0 / 5.5 kW (50 / 60 Hz)
Weight approx.	76 / 83 kg (50 / 60 Hz)	86 / 92 kg (50 / 60 Hz)	95 / 112 kg (50 / 60 Hz)
Dimensions (L x W x H)	517 x 330 x 347 mm	568 x 330 x 347 mm	564 x 330 x 374 mm
Gas inlet / outlet	DN 40 PN 16 / DN 40 PN 16	DN 40 PN 16 / DN 40 PN 16	DN 40 PN 16 / DN 40 PN 16

DO YOU WANT TO KNOW MORE?

Get in touch with us directly!
sales@busch.co.za or +27 (0)11 856 0650



CONTACT FORM



CALL NOW