

R5 KB 0020-0040 D/F

Oil-lubricated rotary vane vacuum pumps



VACUUM SOLUTIONS



Compact

Direct-drive construction, reduced height and weight, ideal for installation in vacuum packaging machines

Reliable

Robust construction, highly durable vanes, proven rotary vane technology, long service life

Flexible

Various design options available, easy adaption to individual customer requirements and processes

Accessories

- Gas-ballast valve
- Filter pressure gauge
- Vacuum pump oils for all applications
- Various inlet filters
- Oil level switch
- Vacuum regulating unit

R5 KB 0020-0040 D/F

Oil-lubricated rotary vane vacuum pumps



VACUUM SOLUTIONS

Dimensional drawing

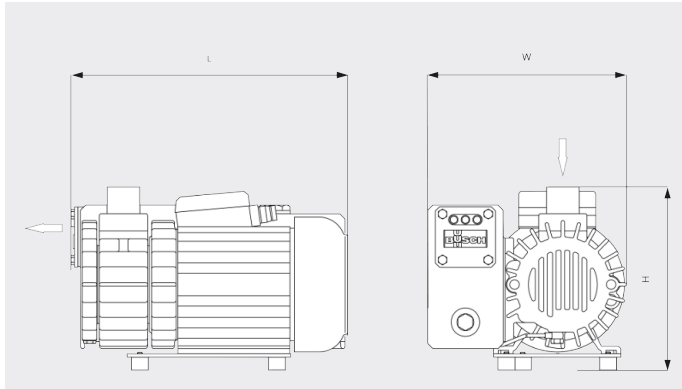

Pumping speed

Air at 20°C. Tolerance: ± 10%

— 50 Hz 60 Hz

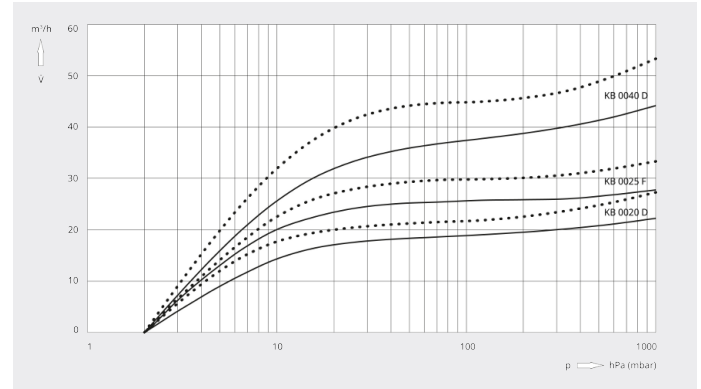

	R5 KB 0020 D	R5 KB 0025 F	R5 KB 0040 D
Nominal pumping speed	14.1 ACFM	17.7 ACFM	28.2 ACFM
Ultimate pressure	1.5 TORR	1.5 TORR	1.5 TORR
Nominal motor rating	1.0 HP	1.5 HP	2.0 HP
Nominal motor speed	3600 RPM	3600 RPM	3600 RPM
Noise level (ISO 2151)	70 dB(A)	73 dB(A)	75 dB(A)
Oil capacity	0.5 qts.	0.5 qts.	0.8 qts.
Weight approx.	41.8 Lbs.	44 Lbs.	63.8 Lbs.
Dimensions (L x W x H)	12.7 x 9.1 x 8.3 inches	13.7 x 9.8 x 9 inches	17 x 10.1 x 9.4 inches
Gas inlet / outlet	G 3/4" / -	G 3/4" / -	G 1 1/4" / G 1 1/4"

DO YOU WANT TO KNOW MORE?

Get in touch with us directly!
info@buschusa.com or +1 757 463 7800



CONTACT FORM



CALL NOW