

R5 RA 0155 A

Oil-lubricated rotary vane vacuum pump



VACUUM SOLUTIONS



Reliable

Robust construction, highly durable fiber-reinforced epoxy resin vanes, proven rotary vane technology, long service life

High performance

High pumping speed at low pressures, designed for continuous operation in the rough vacuum range

Flexible

Easy adaption to individual customer requirements and processes, level and temperature switch as standard

Accessories

- Gas-ballast valve
- Various inlet filters
- Adapter flange for vacuum booster
- Filter pressure gauge
- Vacuum pump oils for all applications
- Oil level switch
- Temperature sensors
- Starter unit
- Oxygen version

R5 RA 0155 A

Oil-lubricated rotary vane vacuum pump



Dimensional drawing

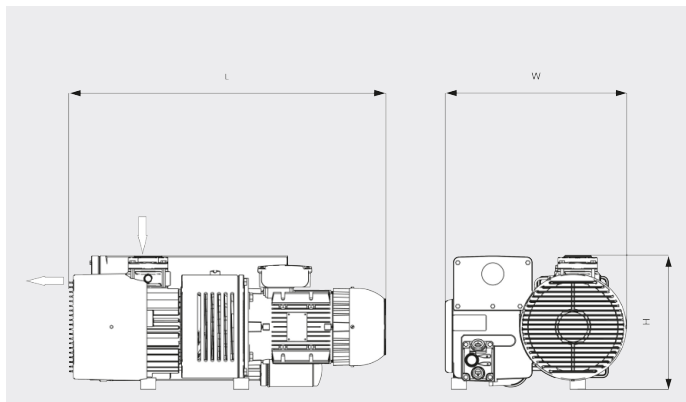

Pumping speed

Air at 70°F. Tolerance: $\pm 10\%$

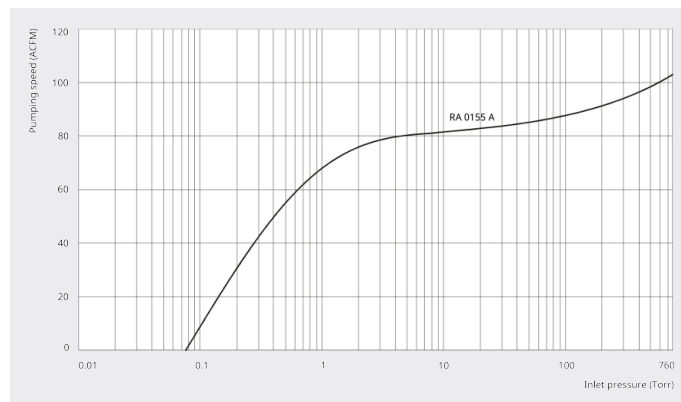

R5 RA 0155 A	
Nominal pumping speed	103 ACFM
Ultimate pressure	0.075 TORR
Nominal motor rating	5 HP
Nominal motor speed	1800 RPM
Power consumption at 75 TORR	4 HP
Power consumption at ultimate pressure	3.3 HP
Noise level (ISO 2151)	72 dB(A)
Oil capacity	3.7 qts.
Weight approx.	243 Lbs.
Dimensions (L x W x H)	32 x 18.5 x 13.4 inches
Gas inlet / outlet	2" NPT / 2" NPT

DO YOU WANT TO KNOW MORE?

Get in touch with us directly!
info@buschusa.com or +1 757 463 7800



CONTACT FORM



CALL NOW