

R5 RE 0040/0063 C

Oil-lubricated rotary vane vacuum pumps



VACUUM SOLUTIONS



Explosion-proof

ATEX-certified to directive 2014/34/EU: II 1/2G Ex h IIB3 T4 Ga/Gb, specially designed to extract explosion endangered gas/air and vapor/air mixtures, suitable for the extraction of almost all substances in the IIB3 explosion group as well as petrol vapor

Reliable

Robust construction, highly durable fiber-reinforced epoxy resin vanes, proven rotary vane technology, long service life

Flexible

Various design options available, easy adaption to individual customer requirements and processes, level and temperature switch as standard

Accessories, spare parts and options

- Gas-ballast valve
- Oil level switch
- Anti-corrosion coating on the oil separator
- T4 motor and transmitter (temperature class T4 outside the vacuum pump)

R5 RE 0040/0063 C

Oil-lubricated rotary vane vacuum pumps



Dimensional drawing

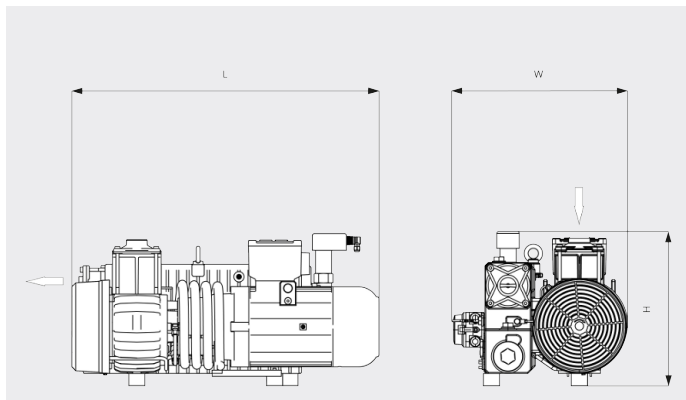

Pumping speed

Air at 20°C. Tolerance: ± 10%

— 50 Hz 60 Hz

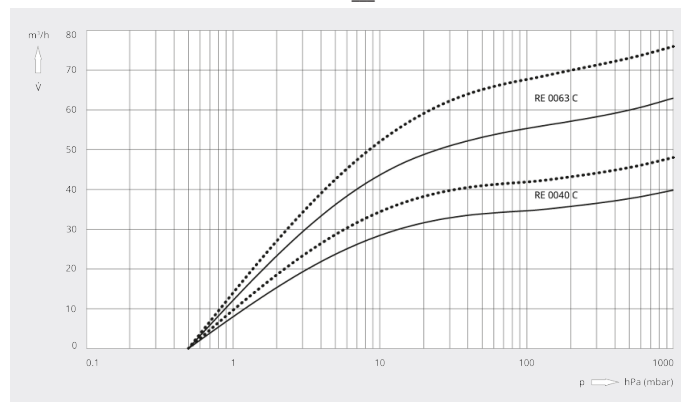

	R5 RE 0040 C	R5 RE 0063 C
Nominal pumping speed	28.2 ACFM	44.7 ACFM
Ultimate pressure	0.375 TORR	0.375 TORR
Nominal motor rating	3.0 HP	3.0 HP
Nominal motor speed	1800 RPM	1800 RPM
Noise level (ISO 2151)	66 dB(A)	68 dB(A)
Oil capacity	2.1 qts.	2.1 qts.
Weight approx.	191.4 Lbs.	200.2 Lbs.
Dimensions (L x W x H)	27.4 x 15.9 x 15 inches	28.4 x 15.9 x 15 inches
Gas inlet / outlet	G 1¼" / G 1¼"	G 1¼" / G 1¼"

DO YOU WANT TO KNOW MORE?

Get in touch with us directly!
info@buschusa.com or +1 757 463 7800



CONTACT FORM



CALL NOW