

# R5 RA 0520 A

Oil-lubricated rotary vane vacuum pump



VACUUM SOLUTIONS



## Efficient

Up to 25% more energy-efficient than comparable rotary vane vacuum pumps, low operating costs, high uptime, reduced heat emission

## High performance

High pumping speed at low pressure ranges, designed for continuous operation in the rough vacuum range, best-in-class footprint performance ratio

## Easy servicing

40% less spare parts, all service-relevant parts on one side, service routine significantly faster, smooth surface design for easy cleaning

# R5 RA 0520 A

Oil-lubricated rotary vane vacuum pump



VACUUM SOLUTIONS

Dimensional drawing

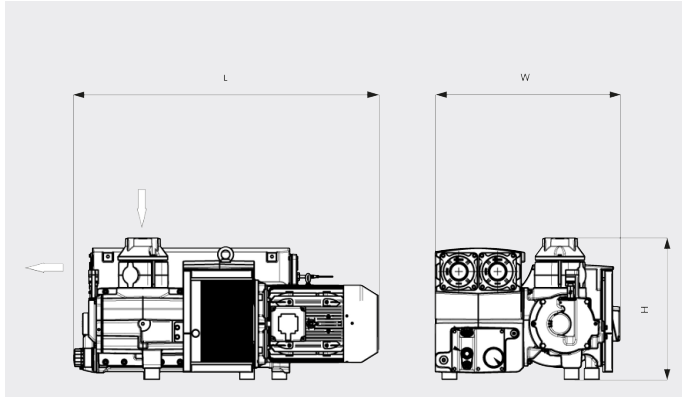

Pumping speed

Air at 70°F. Tolerance: ± 10%

50 Hz ..... 60 Hz

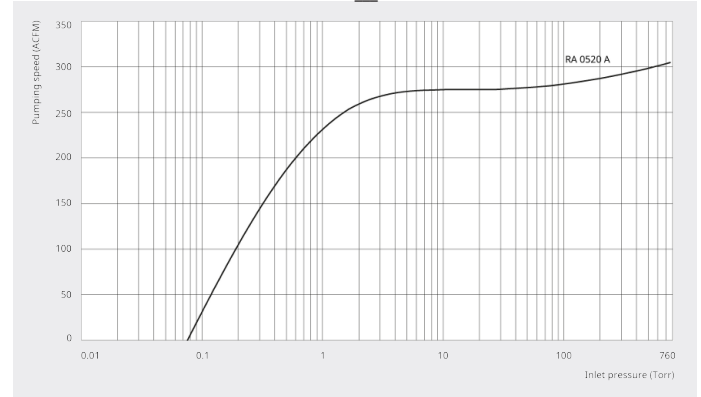

R5 RA 0520 A	
Nominal pumping speed	306.0 ACFM
Ultimate pressure	0.075 TORR
Nominal motor speed	1200 RPM
Power consumption at ultimate pressure	5.8 HP
Noise level (ISO 2151)	79 dB(A)
Oil capacity	11.6 qts.
Weight approx.	858 Lbs.
Dimensions (L x W x H)	49.3 x 28.9 x 22.4 inches
Gas inlet *	G 3"

\*Gas outlet G 3" optional

## DO YOU WANT TO KNOW MORE?

Get in touch with us directly!  
[info@buschusa.com](mailto:info@buschusa.com) or +1 757 463 7800



CONTACT FORM



CALL NOW