

# R5 KD 0025 A

Oil-lubricated rotary vane vacuum pump



VACUUM SOLUTIONS



## Compact

Direct-drive construction, reduced height and weight, specially designed for table top packaging machines

## High performance

Fast pump-down times, high vapor tolerance, excellent condensation protection, optimum temperature management

## Easy servicing

Fast service routine, long service intervals, smooth surface design for easy cleaning

# R5 KD 0025 A

Oil-lubricated rotary vane vacuum pump



VACUUM SOLUTIONS

Dimensional drawing

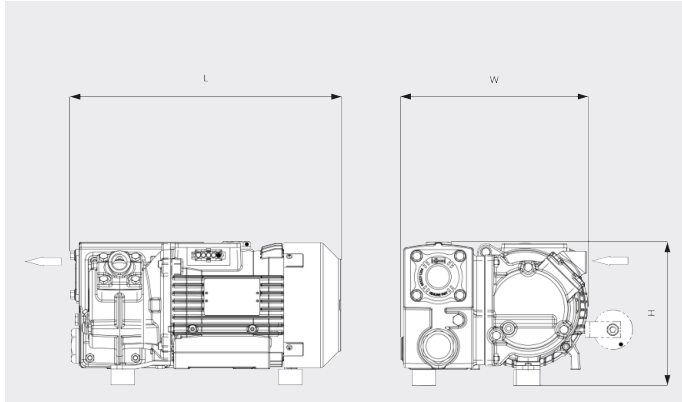

Pumping speed

Air at 70°F. Tolerance: ± 10%     50 Hz     ..... 60 Hz

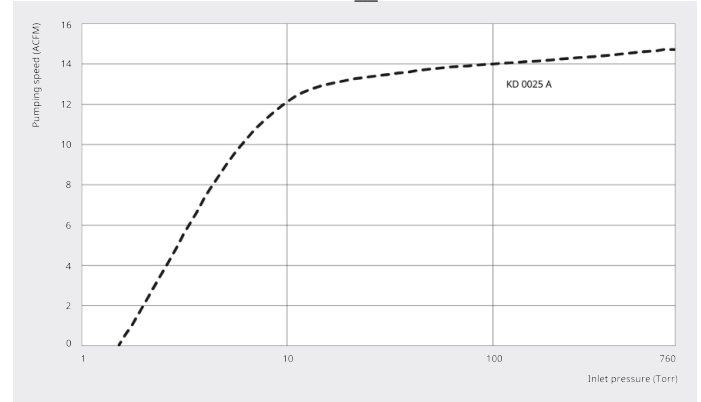

	R5 KD 0025 A short separator	R5 KD 0025 A long separator
Nominal pumping speed	14.7 ACFM	14.7 ACFM
Ultimate pressure	1.5 TORR	1.5 TORR
Nominal motor rating	3600 RPM	3600 RPM
Nominal motor speed	1.2 HP	1.2 HP
Noise level (ISO 2151)	70 dB(A)	68 dB(A)
Oil capacity	0.32 qts.	0.48 qts.
Weight approx.	46.2 Lbs.	46.2 Lbs.
Dimensions (L x W x H)	13.3 x 9.3 x 7.1 inches	13.3 x 9.1 x 7.4 inches
Gas inlet / outlet	G ½" / G ½"	G ½" / G ½"

## DO YOU WANT TO KNOW MORE?

Get in touch with us directly!  
[info@buschusa.com](mailto:info@buschusa.com) or +1 757 463 7800



CONTACT FORM



CALL NOW