

DOLPHIN LA 0756/0906 A

Liquid ring vacuum pumps



VACUUM SOLUTIONS



Robust

Proven technology, durable single-stage construction

Reliable

Extremely high vapor and particle tolerance

Flexible

Wide range of construction materials, including cast iron (EN-GJL-200), many grades of stainless steel and even titanium, ATEX-certified version available (Cat 1(i)/2(o) IIC T5), different operating fluids possible, operation as compressor possible

Accessories, spare parts and options

- Partial or total recirculation systems
- Liquid separator
- Cavitation protection
- Heat exchanger
- Gas ejector
- Wide selection of motors
- Non-return valves
- Vacuum relief valves

DOLPHIN LA 0756/0906 A

Liquid ring vacuum pumps



VACUUM SOLUTIONS

Dimensional drawing

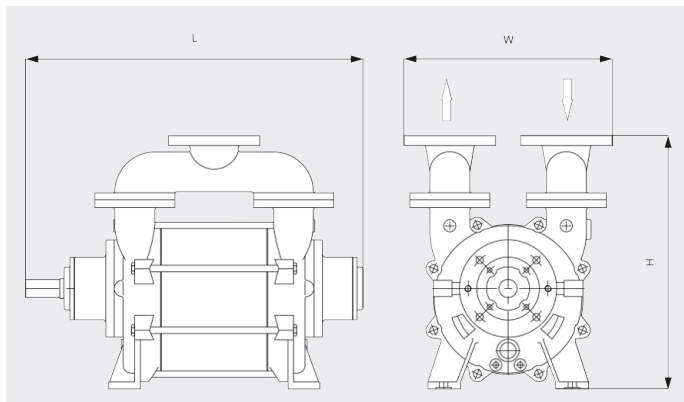

Pumping speed

Air at 70°F. Tolerance: ± 10%

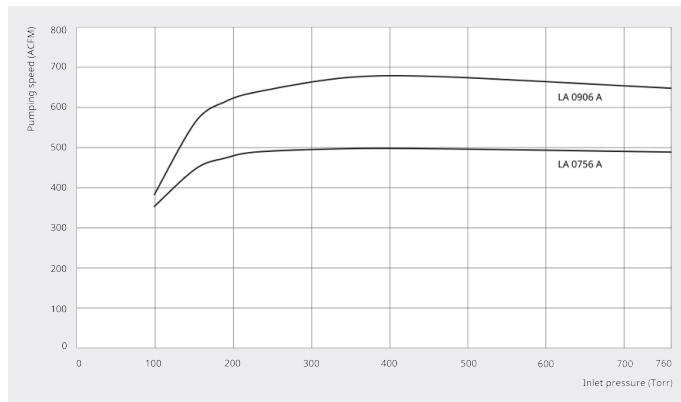

	DOLPHIN LA 0756 A	DOLPHIN LA 0906 A
Nominal pumping speed	497.0 ACFM	686.0 ACFM
Ultimate pressure	100 TORR	100 TORR
Nominal motor rating	40.0 HP	50.0 HP
Nominal motor speed	1750 RPM	1750 RPM
Noise level (ISO 2151)	75 dB(A)	75 dB(A)
Weight approx.	639 Lbs.	705 Lbs.
Dimensions (L x W x H)	33.2 x 15.8 x 24.8 inches	36.3 x 15.8 x 24.8 inches
Gas inlet / outlet	4" / 4"	4" / 4"

DO YOU WANT TO KNOW MORE?

Get in touch with us directly!
info@buschusa.com or +1 757 463 7800



CONTACT FORM



CALL NOW