

DOLPHIN LA 1157-1807 A

Liquid ring vacuum pumps



VACUUM SOLUTIONS



Robust

Proven technology, durable single-stage construction

Reliable

Extremely high vapor and particle tolerance

Flexible

Wide range of construction materials, including cast iron (EN-GJL-200), many grades of stainless steel and even titanium, ATEX-certified version available (Cat 1(i)/2(o) IIC T5), different operating fluids possible, operation as compressor possible

Accessories, spare parts and options

- Partial or total recirculation systems
- Liquid separator
- Cavitation protection
- Heat exchanger
- Gas ejector
- Wide selection of motors
- Non-return valves
- Vacuum relief valves

DOLPHIN LA 1157-1807 A

Liquid ring vacuum pumps



VACUUM SOLUTIONS

Dimensional drawing

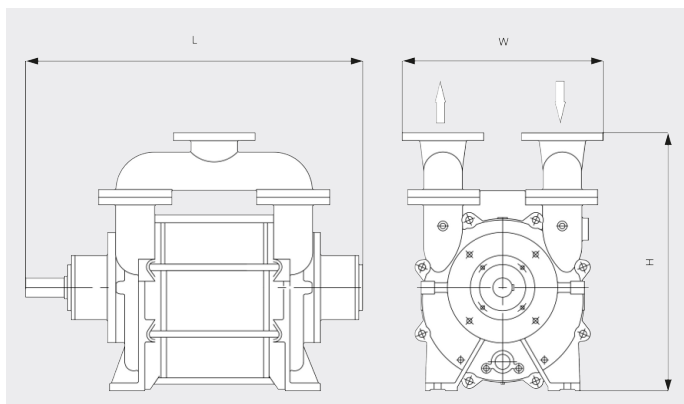

Pumping speed

Air at 70°F. Tolerance: ± 10%

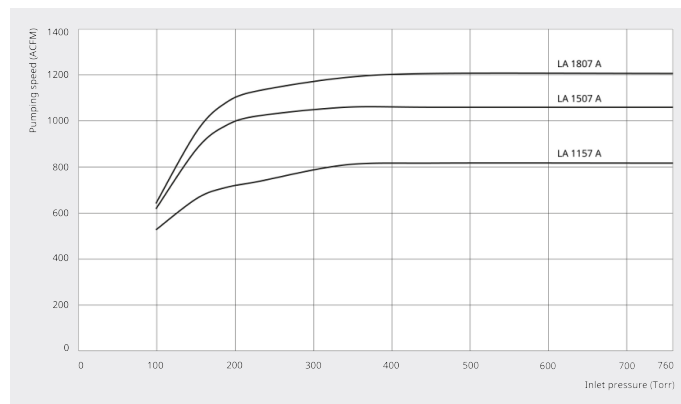

	DOLPHIN LA 1157 A	DOLPHIN LA 1507 A	DOLPHIN LA 1807 A
Nominal pumping speed	817.0 ACFM	1059.0 ACFM	624 – 1207 ACFM
Ultimate pressure	100 TORR	100 TORR	100 TORR
Nominal motor rating	60.0 HP	75.0 HP	60 – 100 HP
Nominal motor speed	1150 RPM	1150 RPM	880 – 1150 RPM
Noise level (ISO 2151)	77 dB(A)	77 dB(A)	77 dB(A)
Weight approx.	1190 Lbs.	1323 Lbs.	1455 Lbs.
Dimensions (L x W x H)	41.2 x 18.9 x 31.5 inches	45.1 x 18.9 x 31.5 inches	49 – 56 x 19 x 31 inches
Gas inlet / outlet	5" / 5"	5" / 5"	5" / 5"

DO YOU WANT TO KNOW MORE?

Get in touch with us directly!
info@buschusa.com or +1 757 463 7800



CONTACT FORM



CALL NOW