

DOLPHIN LA 1908-2808 A

Liquid ring vacuum pumps

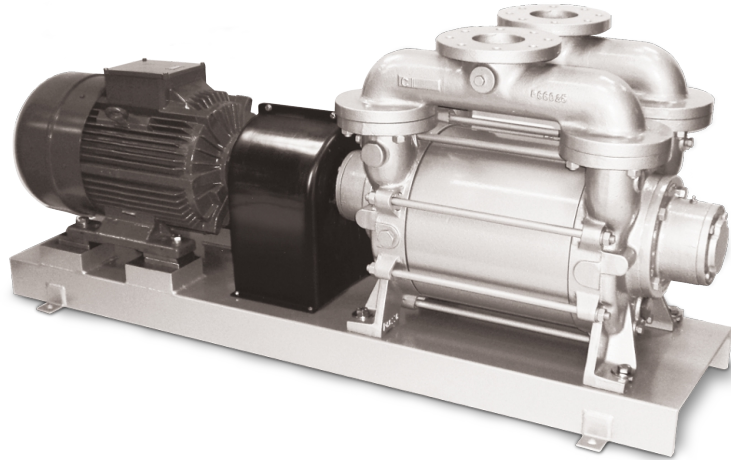

VACUUM SOLUTIONS



Robust

Proven technology, durable single-stage construction

Reliable

Extremely high vapor and particle tolerance

Flexible

Wide range of construction materials, including cast iron (EN-GJL-200), many grades of stainless steel and even titanium, ATEX-certified version available (Cat 1(i)/2(o) IIC T5), different operating fluids possible, operation as compressor possible

Accessories, spare parts and options

- Partial or total recirculation systems
- Liquid separator
- Cavitation protection
- Heat exchanger
- Gas ejector
- Wide selection of motors
- Non-return valves
- Vacuum relief valves

DOLPHIN LA 1908-2808 A

Liquid ring vacuum pumps



VACUUM SOLUTIONS

Dimensional drawing

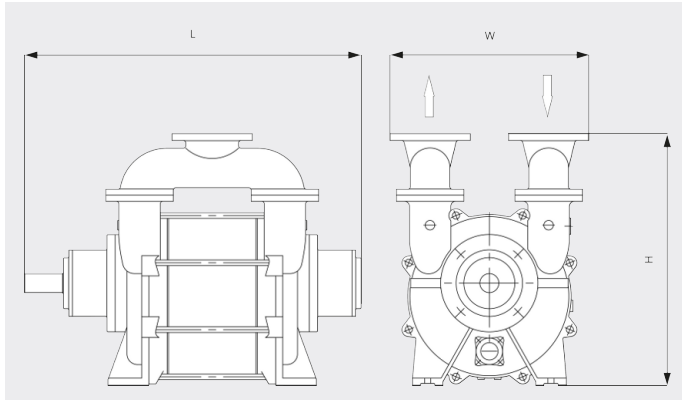

Pumping speed

Air at 70°F. Tolerance: ± 10%

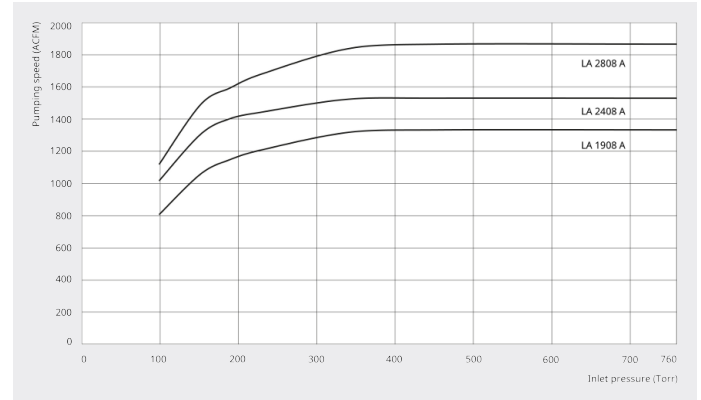

	DOLPHIN LA 1908 A	DOLPHIN LA 2408 A	DOLPHIN LA 2808 A
Nominal pumping speed	1333.0 ACFM	1530.0 ACFM	1866.0 ACFM
Ultimate pressure	100 TORR	100 TORR	100 TORR
Nominal motor rating	125.0 HP	150.0 HP	200.0 HP
Nominal motor speed	880 RPM	880 RPM	880 RPM
Noise level (ISO 2151)	79 dB(A)	79 dB(A)	79 dB(A)
Weight approx.	3086 Lbs.	3417 Lbs.	3748 Lbs.
Dimensions (L x W x H)	55.8 x 25.6 x 41.8 inches	59.8 x 25.6 x 41.8 inches	63.7 x 25.6 x 41.8 inches
Gas inlet / outlet	8" / 8"	8" / 8"	8" / 8"

DO YOU WANT TO KNOW MORE?

Get in touch with us directly!
info@buschusa.com or +1 757 463 7800



CONTACT FORM



CALL NOW