

DOLPHIN LB 0857-1757 A

Liquid ring vacuum pumps



VACUUM SOLUTIONS



Robust

Proven technology, durable two-stage construction

Reliable

Extremely high vapor and particle tolerance

Flexible

Wide range of construction materials, including cast iron (EN-GJL-200), many grades of stainless steel and even titanium, ATEX-certified version available (Cat 1(i)/2(o) IIC T5), operating fluids other than water possible, operation as compressor possible

Accessories, spare parts and options

- Partial or total recirculation systems
- Liquid separator
- Cavitation protection
- Heat exchanger
- Gas ejector
- Wide selection of motors
- Non-return valves
- Vacuum relief valves

DOLPHIN LB 0857-1757 A

Liquid ring vacuum pumps



VACUUM SOLUTIONS

Dimensional drawing

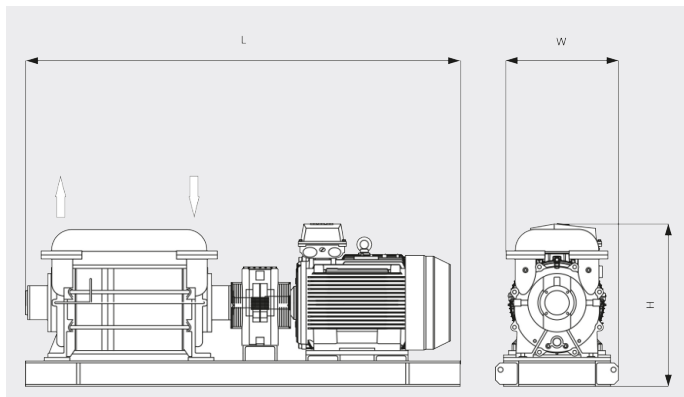

Pumping speed

Air at 20°C. Tolerance: ± 10%

— 50 Hz 60 Hz

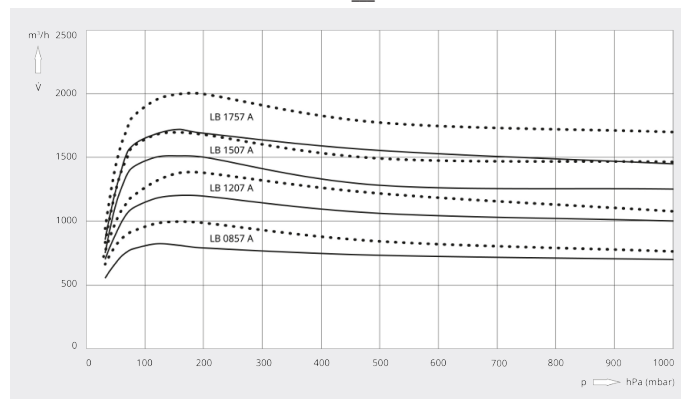

	DOLPHIN LB 0857 A	DOLPHIN LB 1207 A	DOLPHIN LB 1507 A	DOLPHIN LB 1757 A
Nominal pumping speed	586.0 ACFM	813.0 ACFM	995.0 ACFM	1177.0 ACFM
Ultimate pressure	25 TORR	25 TORR	25 TORR	25 TORR
Max. overpressure	29.0 PSIG	29.0 PSIG	29.0 PSIG	29.0 PSIG
Nominal motor rating	60.0 HP	75.0 HP	100.0 HP	125.0 HP
Nominal motor speed	1150 RPM	1150 RPM	1150 RPM	1150 RPM
Noise level (ISO 2151)	77 dB(A)	77 dB(A)	77 dB(A)	77 dB(A)
Weight approx.	1190 Lbs.	1323 Lbs.	1510 Lbs.	1698 Lbs.
Dimensions (L x W x H)	50.5 x 18.9 x 27.9 inches	56.4 x 18.9 x 27.9 inches	60.3 x 19 x 27 inches	66.3 x 18.9 x 27.9 inches
Gas inlet / outlet	4" ANSI / 4" ANSI	4" ANSI / 4" ANSI	4" ANSI / 4" ANSI	4" ANSI / 4" ANSI

DO YOU WANT TO KNOW MORE?

Get in touch with us directly!
info@buschusa.com or +1 757 463 7800



CONTACT FORM



CALL NOW