

DOLPHIN LB 3809/4409 A

Liquid ring vacuum pumps



VACUUM SOLUTIONS



Robust

Proven technology, durable two-stage construction

Reliable

Extremely high vapor and particle tolerance

Flexible

Wide range of construction materials, including cast iron (EN-GJL-200), many grades of stainless steel and even titanium, ATEX-certified version available (Cat 1(i)/2(o) IIC T5), operating fluids other than water possible, operation as compressor possible

Accessories, spare parts and options

- Partial or total recirculation systems
- Liquid separator
- Cavitation protection
- Heat exchanger
- Gas ejector
- Wide selection of motors
- Non-return valves
- Vacuum relief valves

DOLPHIN LB 3809/4409 A

Liquid ring vacuum pumps



VACUUM SOLUTIONS

Dimensional drawing

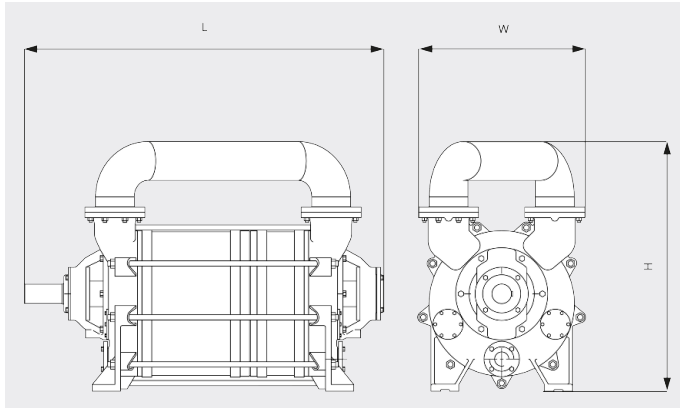

Pumping speed

Air at 70°F. Tolerance: ± 10%

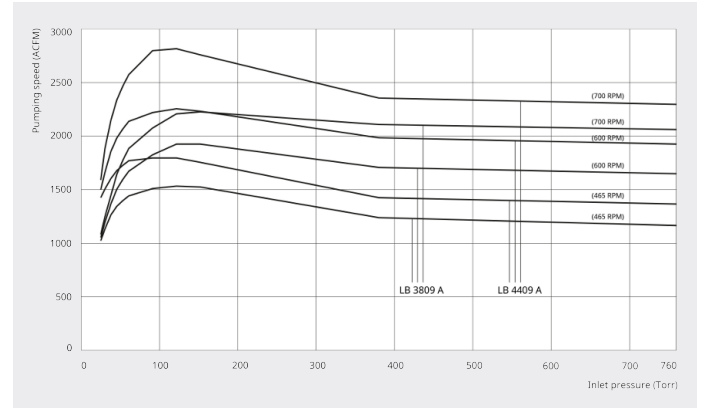

	DOLPHIN LB 3809 A	DOLPHIN LB 4409 A
Nominal pumping speed	2225.0 ACFM	2813.0 ACFM
Ultimate pressure	25 TORR	25 TORR
Nominal motor rating	200.0 HP	250.0 HP
Nominal motor speed	700 RPM	700 RPM
Noise level (ISO 2151)	85 dB(A)	85 dB(A)
Weight approx.	4630 Lbs.	4850 Lbs.
Dimensions (L x W x H)	79.8 x 37.4 x 55.5 inches	94.6 x 37.4 x 55.5 inches
Gas inlet / outlet	8" / 8"	8" / 8"

DO YOU WANT TO KNOW MORE?

Get in touch with us directly!
info@buschusa.com or +1 757 463 7800



CONTACT FORM



CALL NOW