

R5 KD 0012/0020 A

Oil-lubricated rotary vane vacuum pumps



VACUUM SOLUTIONS



Compact

Direct-drive construction, reduced height and weight, specially designed for small packaging machines

Reliable

High vapor tolerance, excellent condensation protection, optimum temperature management

Easy servicing

Fast service routine, long service intervals, smooth surface design for easy cleaning

R5 KD 0012/0020 A

Oil-lubricated rotary vane vacuum pumps



VACUUM SOLUTIONS

Dimensional drawing

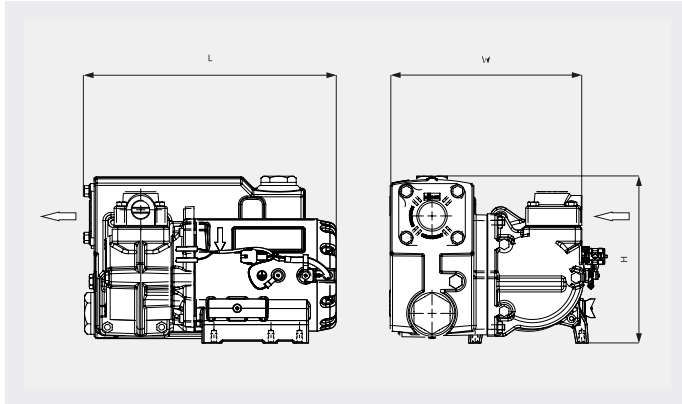

Pumping speed

Air at 70°F. Tolerance: ± 10%

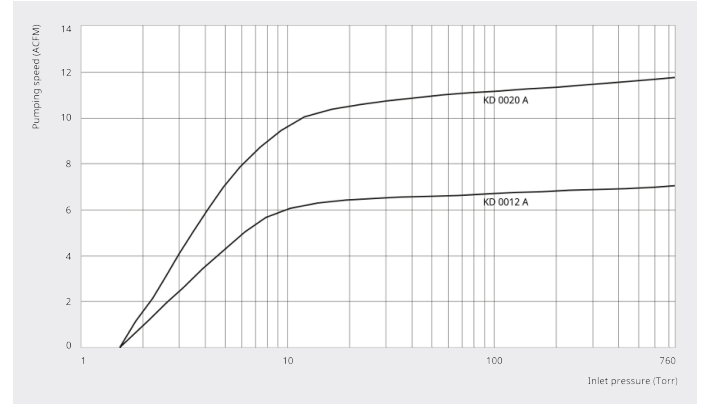

	R5 KD 0012 A	R5 KD 0020 A
Nominal pumping speed	7.1 ACFM	11.8 ACFM
Ultimate pressure	1.5 TORR	1.5 TORR
Nominal motor rating	0.5 HP	0.7 HP
Nominal motor speed	3600 RPM	3600 RPM
Noise level (ISO 2151)	62 dB(A)	62 dB(A)
Oil capacity	0.4 qts.	0.4 qts.
Weight approx.	30.8 Lbs.	33 Lbs.
Dimensions (L x W x H)	10.4 x 8.5 x 6.9 inches	10.4 x 8.5 x 6.9 inches
Gas inlet / outlet	G ½" / G ½"	G ½" / G ½"

DO YOU WANT TO KNOW MORE?

Get in touch with us directly!
info@buschusa.com or +1 757 463 7800



CONTACT FORM



CALL NOW