

MINK MV 0310 B

Dry claw vacuum pump



VACUUM SOLUTIONS



Flexible

Variable speed drive (VSD)

Efficient

Latest claw technology, additional pumping speed thanks to pressure control, up to 20% more performance, low energy consumption, minimized operating costs, nearly maintenance-free

Quiet

Low noise level due to a state-of-the-art acoustic design, can be installed at workstations

MINK MV 0310 B

Dry claw vacuum pump



VACUUM SOLUTIONS

Dimensional drawing

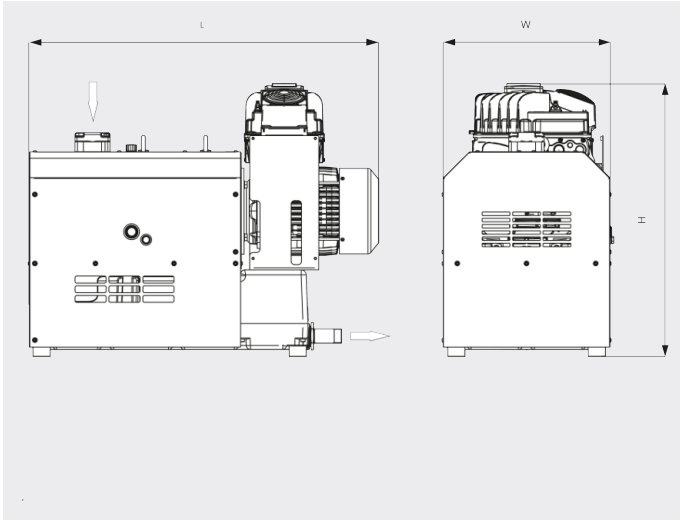

Pumping speed

Air at 20°C. Tolerance: ± 10%

___ 20 Hz 60 Hz

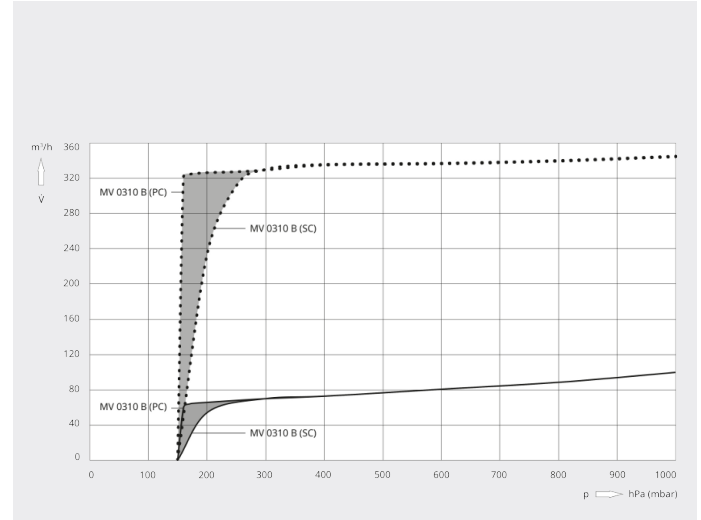

MINK MV 0310 B	
Nominal pumping speed	203 ACFM
Ultimate pressure	112.5 TORR
Nominal motor rating	8.0-10.7 HP
Nominal motor speed	1200-3600 RPM
Noise level (ISO 2151)	72 dB(A)
Weight approx.	748 Lbs.
Dimensions (L x W x H)	40 x 19.7 x 31.1 inches
Gas inlet / outlet	G 2" / R 1 ¼"

DO YOU WANT TO KNOW MORE?

Get in touch with us directly!
info@buschusa.com or +1 757 463 7800



CONTACT FORM



CALL NOW