

R5 RA 1000/1600 A PLUS

Oil-lubricated rotary vane vacuum pumps



VACUUM SOLUTIONS



Control and monitoring

Ready for Industry 4.0 providing remote control, condition monitoring and communication protocols

Cost savings

Reduced energy consumption and minimized operating costs

Proven technology

Reliable operation thanks to R5 rotary vane vacuum technology

R5 RA 1000/1600 A PLUS

Oil-lubricated rotary vane vacuum pumps



VACUUM SOLUTIONS

Dimensional drawing

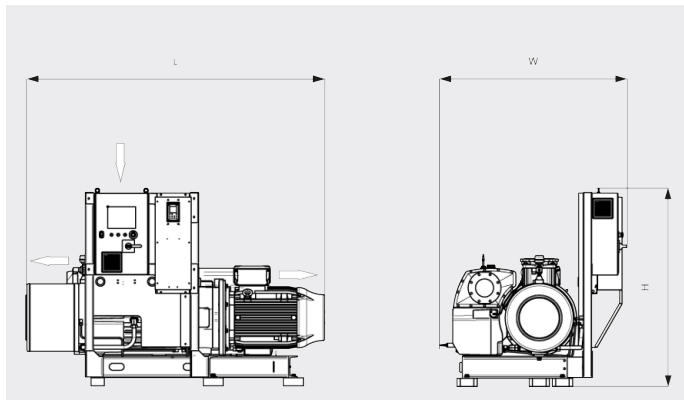

Pumping speed

Air at 70°F. Tolerance: ± 10%

— Min. speed Max. speed

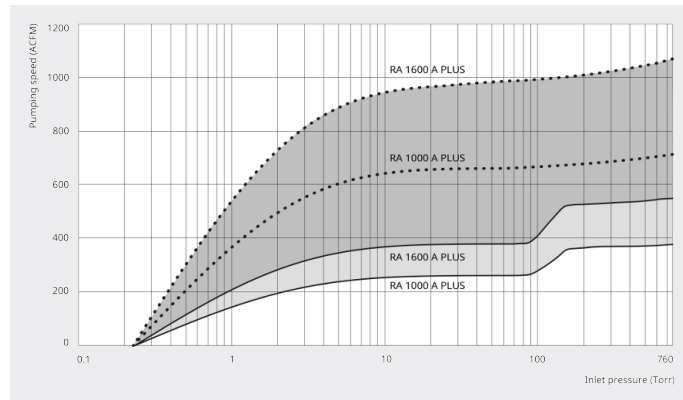

	R5 RA 1000 A PLUS	R5 RA 1600 A PLUS
Nominal pumping speed	258.9–706.2 ACFM	376.6–1059.3 ACFM
Ultimate pressure	0.225 TORR	0.225 TORR
Nominal motor rating	40 HP	50 HP
Nominal motor speed	500–1200 RPM	500–1200 RPM
Power consumption at 75 TORR	11.5–29.9 HP	17.1–48.1 HP
Power consumption at ultimate pressure	7.2–16.8 HP	9.3–25.4 HP
Noise level (ISO 2151)	65–79 dB(A)	69–83 dB(A)
Oil capacity	31.7 qts.	31.7 qts.
Weight approx.	2706 Lbs.	3476 Lbs.
Dimensions (L x W x H)	77.3 x 56 x 57.1 inches	86.5 x 56 x 57.1 inches
Gas inlet / outlet	DN 150 / DN 125	DN 150 / DN 125

DO YOU WANT TO KNOW MORE?

Get in touch with us directly!
info@buschusa.com or +1 757 463 7800



CONTACT FORM



CALL NOW