

# MINK MV 0312 B

Dry claw vacuum pump



VACUUM SOLUTIONS



## Quiet

Low noise level due to a state-of-the-art acoustic design, can be installed at workstations

## Efficient

Latest claw vacuum technology, low energy consumption, minimized operating costs, nearly maintenance-free, effective air cooling

## Compact

Small footprint

# MINK MV 0312 B

Dry claw vacuum pump



VACUUM SOLUTIONS

Dimensional drawing

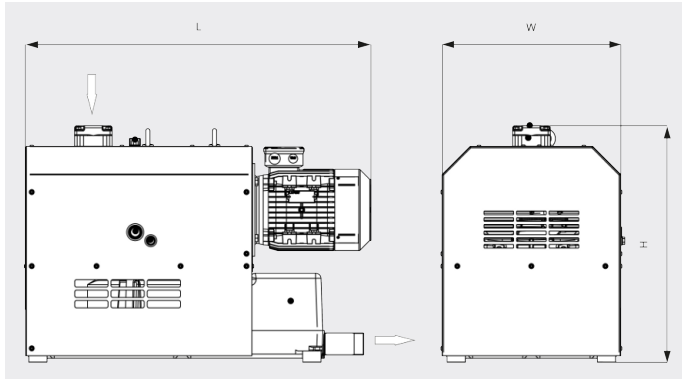

Pumping speed

Air at 70°F. Tolerance:  $\pm 10\%$

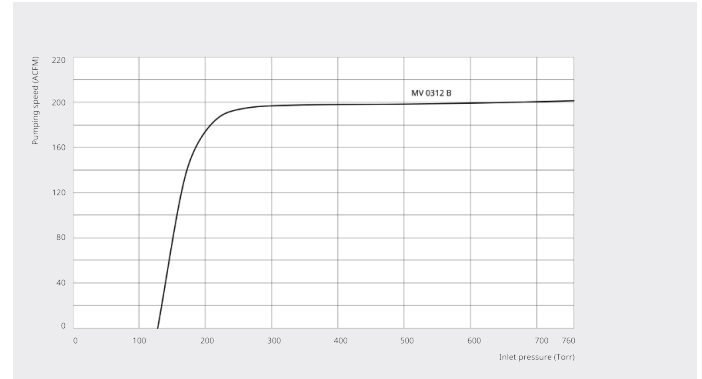

MINK MV 0312 B	
Nominal pumping speed	203 ACFM
Ultimate pressure	112.5 TORR
Nominal motor rating	8.7 HP
Nominal motor speed	3600 RPM
Noise level (ISO 2151)	72 dB(A)
Weight approx.	660 Lbs.
Dimensions (L x W x H)	37 x 19.5 x 25.6 inches
Gas inlet / outlet	G 2" / R 1¼"

## DO YOU WANT TO KNOW MORE?

Get in touch with us directly!  
[info@buschusa.com](mailto:info@buschusa.com) or +1 757 463 7800



CONTACT FORM



CALL NOW