

# Instruction Manual

## COBRA

Screw Vacuum Pumps  
DS 0600 E PE



Get technical data,  
instruction manuals,  
service kits



**VACUUM APP**

# Table of contents

Preface	2
COBRA DS 0600 E PE	3
Product description	4
Use	4
Operating principle	4
Oil circuit	5
Cooling	5
Optional functions/ Use of available accessories	5
On/ Off switch	5
Safety	5
Intended use	5
Safety information	5
Safety stickers	6
Noise emission	6
Maintenance clearance	6
Electrical safety	6
Types of Electrical Work	6
Type 1	6
Type 2	6
Type 3	6
Type 4	7
Lock Out/ Tag Out procedure (Type 1 of electrical work)	7
Safety Lockout procedure	7
Emergency off circuit description	7
Lock out/ Tag out for hydraulics and pneumatics	7
Lock Out/ Tag Out procedure (Type 1 of electrical work)	7
Transport	7
Transport in packed state	7
Transport in unpacked state	7
Storage	8
Temporary storage	8
Removal of the pump	8
Preservation	8
Start-up of the vacuum pump after storage	8
Installation and start-up	8
Necessary installation instructions	8
Installation site and installation	8
Inlet connection	9
Discharge connection	9
Cooling water connection	9
Nitrogen connection	9
Electrical connection/ Checks	9
Installation	9
Mounting	9
Electrical connection	10
Connection of supply cable to control box	10
Equipment connections (with options)	11
Connection of the lines/ pipes	11
Oil filling	11
Oil level, pump not operating	11
Filling in cooling liquid	12
Checking the direct cooling	12
Saving the operating parameters	12
Recommendations on operation	12
Application	12
Switching the vacuum pump on/ off	13
First start-up of the system	13
Switching the system off	13
Maintenance	13
Maintenance program	14
Weekly	14
Monthly	14
Yearly	14
Every 16 000 hours of operation, at the latest after 4 years	14
Lock Out/ Tag Out procedure	14
Safety Lockout procedure	14
Checking the oil	15
Checking the oil level	15
Oil level, pump not operating	15
Refilling oil	15
Checking the colour of the oil	15
Oil change	15
Draining used oil	15
Filling in new oil	16

Oil level, pump not operating	16
Checking the cooling liquid	16
Checking the level of the cooling liquid	16
Refilling cooling liquid	16
Draining the cooling liquid	16
Filling in new cooling liquid	16
Checking the cooling water	17
Checking the cooling water flow	17
Checking the nitrogen	17
Checking the nitrogen flow	17
Checking the current consumption	17
Checking the sound absorber (accessory)	17
Checking the leak-protection non-return valve (accessory)	17
Overhaul	17
Removal from service	17
Temporary removal from service	17
Recommissioning	17
Dismantling and disposal	18
Oil type/ quantity	19
Oil type	19
Oil quantity	19
Cooling liquid type/ quantity	20
Cooling liquid type	20
Cooling liquid quantity	20
Technical data	21
EU-Declaration of Conformity	22
UK-Declaration of Conformity	23

## Preface

Congratulations on your purchase of the Busch vacuum pump. With watchful observation of the field's requirements, innovation and steady development Busch delivers modern vacuum and pressure solutions worldwide.

These operating instructions contain information for

- product description,
- safety,
- transport,
- storage,
- installation and commissioning
- maintenance,
- overhaul and
- troubleshooting

of the vacuum pump.

For the purpose of these instructions, "handling" the vacuum pump means the transport, storage, installation, commissioning, influence on operating conditions, maintenance, troubleshooting and overhaul of the vacuum pump.

**Prior to handling the vacuum pump these operating instructions shall be read and understood. If anything remains to be clarified please contact your Busch representative.**

**Keep these operating instructions and, if applicable, other pertinent operating instructions available on site.**

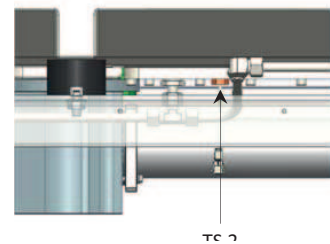
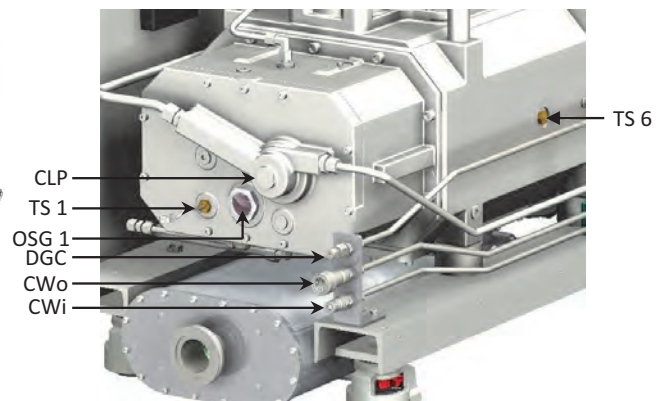
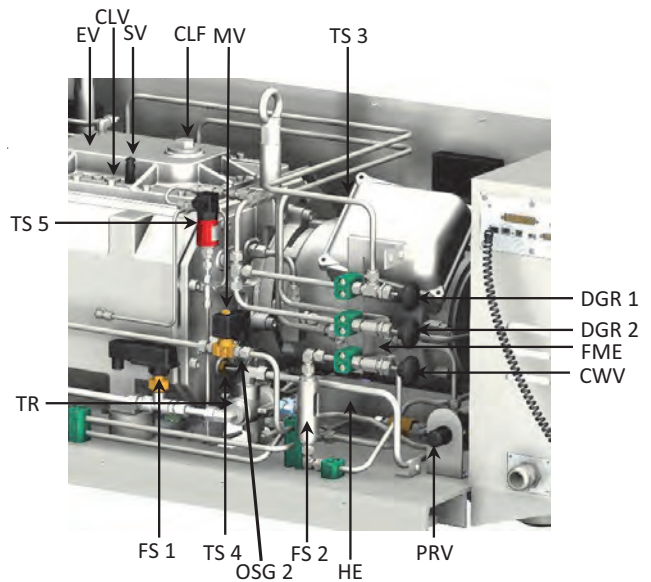
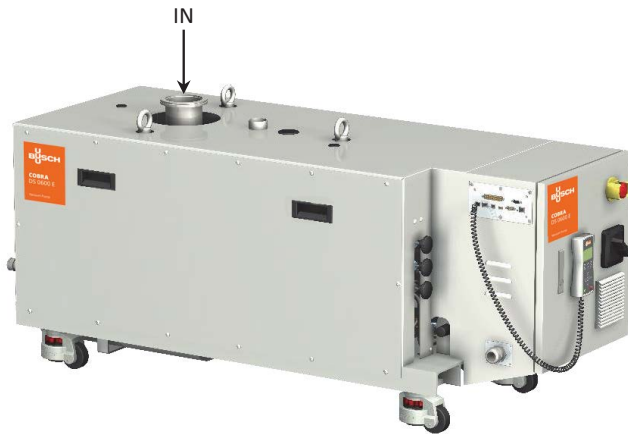

## COBRA DS 0600 E PE

CLF Cooling liquid filler plug  
 CLP Glycol recirculating pump  
 CLV Cooling liquid purge plug  
 CWo Cooling water connection  
 CWi Cooling water connection  
 CWV Regulating valve, cooling water  
 DGC Nitrogen connection  
 DGR 1 Regulating valve, dilution gas (middle of cylinder)  
 DGR 2 Regulating valve, dilution gas (end of cylinder)  
 EV Expansion vessel  
 FME Flow meter, nitrogen  
 FS 1 Flow switch, cooling liquid  
 FS 2 Flow switch, cooling water  
 HE Heat exchanger

IN Inlet  
 MV Solenoid valve, nitrogen system  
 OUT Discharge (to silencer)  
 OSG 1 Oil sight glass  
 OSG 2 Oil sight glass  
 SV Safety valve  
 TR Temperature regulator, 55°C  
 TS 1 Temperature switch, oil temperature 120°C  
 TS 2 Temperature switch, cooling liquid temperature 100°C  
 TS 3 Temperature sensor PT100  
 TS 4 Temperature switch, oil temperature 140°C  
 TS 5 Overpressure sensor  
 TS 6 Temperature switch, motor 155 °C

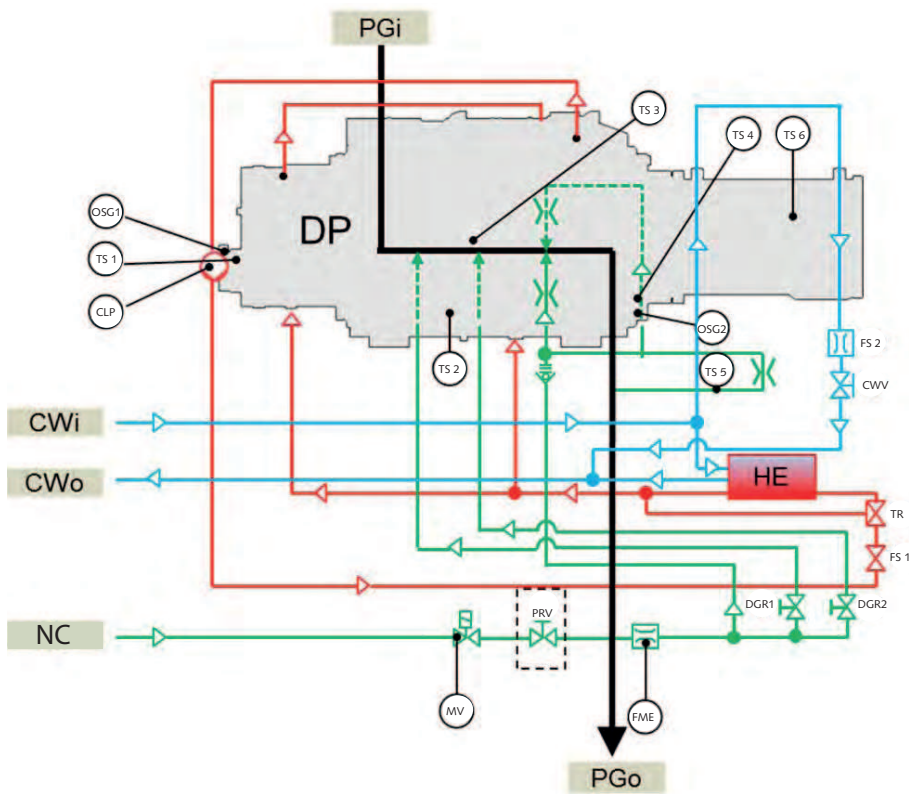

- CLP Glycol recirculating pump
- CWi Cooling water connection
- CWo Cooling water connection
- CWV Regulating valve, cooling water
- DGC Nitrogen connection
- DGR 1 Regulating valve, dilution gas (middle of cylinder)
- DGR 2 Regulating valve, dilution gas (end of cylinder)
- FME Flow meter, nitrogen
- FS 1 Flow switch, cooling liquid
- FS 2 Flow switch, cooling water
- HE Heat exchanger
- MV Solenoid valve, nitrogen system
- OSG 1 Oil sight glass
- OSG 2 Oil sight glass
- TR Temperature regulator, 55°C
- TS 1 Temperature switch, oil temperature 120°C
- TS 2 Temperature switch, cooling liquid temperature 100°C
- TS 3 Temperature sensor PT100TS 4 Temperature switch, oil temperature 140°C
- TS 5 Overpressure sensor
- TS 6 Temperature switch, motor 155 °C
- PRV Regulating valve, nitrogen

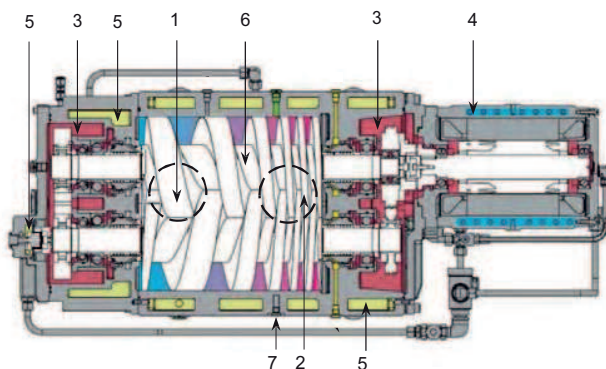

- 1 Inlet
- 2 Discharge
- 3 Oil
- 4 Cooling water
- 5 Cooling liquid
- 6 Screw rotors
- 7 Temperature sensor (option)

## Product description

### Use

The COBRA DS vacuum pumps are designed for use in the field of microelectronics and similar industries.

They can be used to suck gases and gas mixtures.



#### WARNING

**When using toxic, inflammable and/or explosive gases, make sure that the system corresponds in design to applicable local and national safety regulations and that all applicable safety measures are followed.**

**All product-specific safety regulations must be observed.**

Solid particles must not get into the vacuum pump. Procedural errors can result in the pump sucking in a certain quantity of liquid. If the pump has sucked in liquid, a short drying time is necessary at the end of the procedure.

The allowed maximum inlet gas temperature depends on the inlet pressure and the type of gas: the lower the inlet pressure (Pa), the higher the drawn gas temperature (TGas) can be.

The following indicative values for air can be considered:

- Pa > 50 mbar, TGas < 80°C
- Pa < 50 mbar, TGas < 200°C

The vacuum pump is intended for use in a potentially non-explosive environment.

The vacuum pump is thermally suitable for continuous operation at any pressure between atmospheric pressure and ultimate pressure.

The vacuum pump is tight down to ultimate pressure.

### Operating principle

The COBRA DS 0600 E PE vacuum pumps are COBRA NS screw vacuum pumps with cooling water and nitrogen circuits.

The COBRA NS screw vacuum pumps work by the principle of spiral pumps. Two parallel screws (8) rotate in opposite directions in the pump body. Entering gases are trapped between the flights of the screws and the pump body. The gases are conveyed by the rotation of the screws to the exhaust, where they are discharged.

The COBRA NS screw vacuum pumps are driven by water-cooled motors.



## Oil circuit

Since the complete operating principle works without contact, no oil circuit is needed in the work area.

## Cooling

The vacuum pump is cooled by

- the filling of cooling liquid (mix of water and glycol) inside the water chambers (6) of cylinder and endplate of cylinder B-side. An indirect circuit is made with a water pump mounted at the endplate of cylinder B-side. The flow of the cooling water is controlled by a flow switch FS 1. If the flow is under 1 l/min during a minimum time of 30 seconds, then the pump stops. The temperature switch TS 2 will give an emergency signal if the temperature of the cooling liquid is above 100°C. The pump will stop immediately after the emergency alarm ring.
- a direct cooling water circuit in the motor. This circuit is active at start-up.
- a direct cooling water circuit in the motors in the cylinder covers A- and B-side of COBRA NS vacuum pump. The cooling water flow is preset at 8 NI/min at the factory and can be adjusted with valve CWV. The flow is controlled by flow switch FS 2. The cooling water circuit stabilizes the temperature of cooling liquid. When flow is too low a warning then an alarm signal is generated by flow switch FS 2 to the PLC. Status of the pump depends on the alarm function set by user (factory setting: EMO, pump stops after alarm condition)

**NOTE:** The COBRA DS 0600 E PE vacuum pumps are generally dispatched with oil and cooling liquid already in the vacuum pump but, without cooling water. Before vacuum pump first startup, control the oil level and the cooling liquid the level. In the event of absence of one or the other of these lubricants, please carry out the filling (please refer to the various chapters of filling). Do not forget to connect the cooling water supply before the first startup. Operation without these coolants can result in damage to the vacuum pump.

## Optional functions/ Use of available accessories

The safetyvalve (SV) prevents excessively high pressure in the expansion vessel (EV), relief pressure: 6 bar.

A pressure switch (optional) with normally closed contact mounted in the expansion tank monitors the pressure of the cooling liquid. It must be connected in such a way that actuation causes the vacuum pump to be switched off when the pressure exceeds a value of 3 bar.

A pressure switch mounted at the exhaust, controls the overpressure at the exhaust. If overpressure is above 0,2 bar, pressure switch gives a warning then an alarm signal. Status of the pump depends on the alarm function set by user (factory setting : None, pump continues running with an alarm).

A temperature sensor PT100 (10) mounted on the cylinder, measures the temperature inside the cylinder.

A silencer or sound absorber (accessory) at the exhaust reduces the noise of the pump and collects any condensate.

A leak-protection non-return valve (optional) at the exhaust traps the condensate in the pump when the pump is switched off.

The nitrogen can also be used as flushing gas. Depending on the application, flushing is recommended after every use to ensure troublefree operation of the vacuum pump.

The LCD controller processes the data of the sensors as follows:

- discharge pressure
- temperature in the cylinder
- current
- nitrogen flow rate
- cooling water flow rate
- oil temperature
- control of the cooling liquid flow
- cooling liquid temperature

See "Installation and Maintenance Instructions, Busch PLC and Busch LCD (No. 0870758077)".

## On/ Off switch

The vacuum pump is delivered with a circuit breaker. The function start/ stop can be done in Local by using the LCD controller or in Remote by the production machine.

## Safety

### Intended use

**DEFINITION:** To rule out any misunderstanding, the term "handling" of the vacuum pump covers transport, storage, installation and operation of the pump as well as effects on operating states and troubleshooting on the vacuum pump.

The vacuum pump is intended for industrial use. It may only be operated by qualified personnel.

The different application possibilities and limit values for operation described in "Product description" and "Installation requirements" must be observed by the manufacturer of the system into which the vacuum pump is to be integrated and by users.

The need for personal safety regulations depends in principle on the type of use. The operator must provide the users with the necessary means and must inform his personnel about the dangers emanating from the processed product.

The operator of the vacuum pump must observe the safety regulations and must train and instruct his personnel accordingly.

Local regulations regarding the motors and electric control elements must be observed when installing the pump in potentially explosive environments.

The maintenance instructions must be followed and observed.

These installation and maintenance instructions must be read and understood before the vacuum pump is used. If you have any doubts, contact your Busch representative.

### Safety information

The vacuum pump is designed and manufactured in compliance with the latest technical standards and safety regulations. Nevertheless an element of residual risk remains.

Various safety instructions are to be found in this handbook and on the pump. These instructions must be followed. You can recognise these instructions by the signal words DANGER, WARNING and CAUTION, which are defined as follows:



**DANGER**

Disregard of this safety instruction will always result in death, serious injuries or severe damage.



**WARNING**

Disregard of this safety instruction may result in death, serious injuries or severe damage.



**CAUTION**

Disregard of this safety instruction may result in minor or moderate injuries or damage.

## Safety stickers

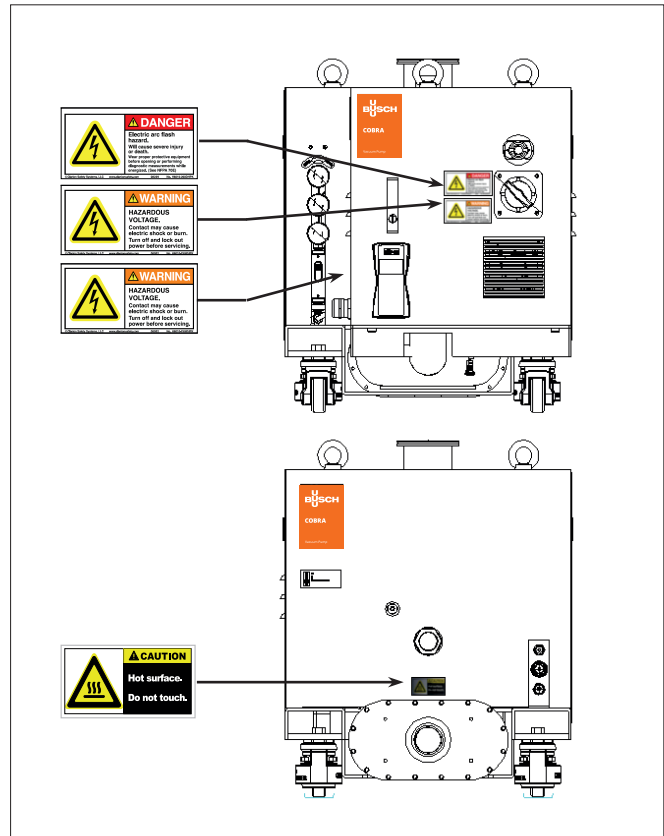
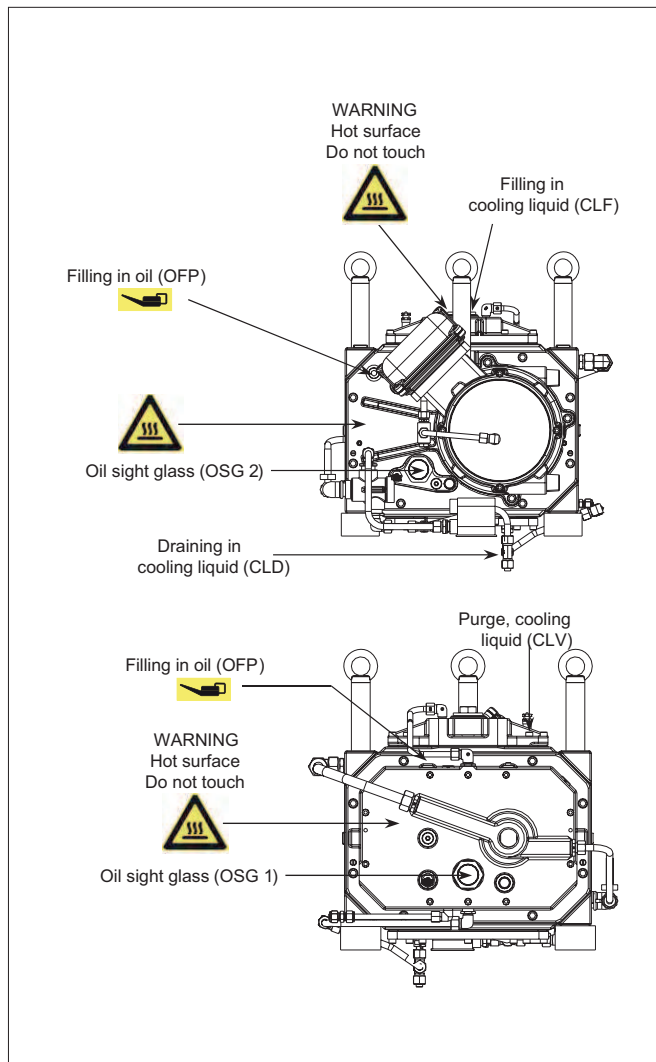

## Noise emission

Refer to the table "Technical data" for the permissible noise level in free field conditions according to EN ISO 2151.



The intensity of the noise of the vacuum pump is higher within a certain area of the pump.

Risk of hearing damage.

Users must wear ear protection when spending a longer period of time in the vicinity of a non-insulated vacuum pump.

## Maintenance clearance

Before any maintenance action, ensure a maintenance clearance around the pump of min. 610 [mm].

## Electrical safety

### Types of Electrical Work

The following are the four types of electrical work defined by the SEMI S2, latest version, guideline:

#### Type 1

Equipment is fully deenergized.

#### Type 2

Equipment is energized. Energized circuits are covered or insulated.

**NOTE :** Type 2 work includes tasks where the energized circuits are or can be measured by placing probes through suitable openings in the covers or insulators.

#### Type 3

Equipment is energized. Energized circuits are exposed and inadvertent contact with uninsulated energized parts is possible. Potential exposures are no greater than 30 volts rms, 42.4 volts peak, 60 volts dc or 240 volt-amp in dry locations.

## Type 4

Equipment is energized. Energized circuits are exposed and inadvertent contact with uninsulated energized parts is possible. Potential exposures are greater than 30 volts rms, 42.4 volts peak, 60 volts dc, or 240 volt-amp in dry locations. Potential exposures to radio-frequency currents, whether induced or via contact, exceed the limits in Table A5-1 of Appendix 5 (SEMI S2 guideline).

### Lock Out/ Tag Out procedure (Type 1 of electrical work)

- Stop the pump with the remote control (press on STOP button during 10s)
- Press on emergency stop button
- Switch off the main disconnect switch
- Switch off the customer's power supply
- Switch off the water and nitrogen quick connections (inlet first, then outlet)
- Put the label or warning board "Maintenance processing" on or next to the pump

### Safety Lockout procedure

- Take off the label or warning board "Maintenance processing"
- Check the cooling liquid and oil levels according to the chapters "Checking the oil level" and "Checking the cooling liquid level"
- Switch on the main disconnect switch
- Release the emergency stop button
- Switch on the water and nitrogen quick connections (outlet first, then inlet)
- Start the pump with the remote control (press on START button)

### Emergency off circuit description

- The Emergency off circuit may be opened by pressing on emergency stop button. If this element shows, then the pump will immediately stop. The PLC will remain energized to save the pump status.
- If the emergency stop button was pressed, check the start up of the pump then release this button to restart the pump. Press on Start button on the remote control, the pump will restart.

### Lock out/ Tag out for hydraulics and pneumatics

- ◆ Hydraulics: cooling water
- ◆ Pneumatics: nitrogen

### Lock Out/ Tag Out procedure (Type 1 of electrical work)

- Stop the pump with the remote control (press on STOP button during 10s)
- Press on emergency stop button
- Switch off the main disconnect switch
- Switch off the customer's power supply
- Switch off the water and nitrogen quick connections (inlet first, then outlet)
- Put the label or warning board "Maintenance processing" on or next to the pump

The end user is responsible for providing energy isolation capabilities on the water and nitrogen

## Transport

The COBRA DS vacuum pumps are tested and checked in our factory before careful packing. Check the packaging for transport damage when the goods arrive. The pump can withstand temperatures between -25°C and +55°C during transport.

### Transport in packed state

Packed on a pallet, the vacuum pump can be moved with a hand forklift truck.

### Transport in unpacked state

The vacuum pump is fastened to the pallet with fixing pins:

- ◆ Unscrew the fastening nuts underneath the pallet.



CAUTION

Do not work, walk or stand under suspended loads.



CAUTION

Please check out the weight of the vacuum pump before lifting it up (see "Technical Data").

Use adequate lifting gear for this.

**NOTE:** The suspension eyes are located at about the center-of-gravity of the vacuum pump. If the vacuum pump is equipped with accessories that could influence the center-of-gravity, this must be taken into account when lifting and a belt must additionally be attached to a specific point.



- Fasten the hoist to the suspension eye(s) on the cylinder
- Use a hoist that is equipped with a hook and safety lock
- Lift the vacuum pump

If the pump is fastened to a pallet with fixing pins:

- ◆ Unscrew the fixing pins in the base frame



CAUTION

In case of a vacuum pump filled with oil, make sure that by lifting the inclination angle of the vacuum pump do not exceed 5° from the horizontal. In case of too high inclination (>5°), risk of oil leak within the work area.

Make sure before every transport using the appropriate lifting mean that the inclination of the vacuum pump is less than 5°.

The packaging material must be disposed of in accordance with local and national regulations.

This handbook is contained in the delivery package.

## Storage

### Temporary storage

- Make sure that the intake and exhaust flanges are closed (put on the protective caps included in the delivery package of the vacuum pump)
- Store the vacuum pump
  - if possible, the vacuum pump should be stored in its original packaging,
  - indoors,
  - dry,
  - in a dust-free and
  - vibration-free room

### Removal of the pump

Before starting a vacuum pump that has been stored outside the building for a while, the vacuum pump must be moved to a room with ambient temperature, where it should rest for a day.

### Preservation

If the vacuum pump will be exposed to unfavourable ambient conditions (for example, aggressive environment, frequent temperature changes), begin immediately with preservation work on the vacuum pump.

In the case of favourable ambient conditions, perform preservation work on the vacuum pump if a storage period of more than three months is planned.

- Make sure that all openings are hermetically sealed; use adhesive tape to fasten loose parts (seal rings, flat seals, etc.).

**NOTE:** VCI is the abbreviation for “volatile corrosion inhibitor”. The VCI molecule is an organic corrosion inhibitor in the vapour phase. Integrated in various carriers such as film, cardboard, paper, foam, liquid and powder, it protects the parts against corrosion as a result of its action in the vapour phase. However, VCI packaging can attack synthetic surfaces and surfaces of other elastomers. If in doubt, please contact your nearest distributor. VCI packaging provides several years of protection against corrosion, even under the harshest of conditions: overseas shipment, extended storage before use.

- Wrap the vacuum pump in a VCI film
- Store the vacuum pump
  - if possible, the vacuum pump should be stored in its original packaging,
  - indoors,
  - dry,
  - in a dust-free and
  - vibration-free room

### Start-up of the vacuum pump after storage:

- Make sure that all protective elements, stoppers or adhesive tapes attached before preservation have been removed
- Switch on the vacuum pump in the sequence described in the chapter “Installation and start-up”

## Installation and start-up

### Necessary installation instructions



CAUTION

If the necessary installation instructions are not followed and particularly in the case of inadequate cooling:

Risk of damage to and total destruction of the vacuum pump and its components!

Risk of personal injury!

The necessary installation instructions must be followed.

- Make sure that the integration of the vacuum pump in its new environment complies with the safety regulations according to the Machinery Directive 2006/42/EC (regarding the responsibility of the manufacturer of the system in which the vacuum pump is to be integrated, see information in the EU-Declaration of Conformity).



WARNING

**Local regulations regarding the motors and electric control elements must be observed when installing the pump in potentially explosive environments. Make sure before start-up that all safety measures have been followed.**

### Installation site and installation

- Make sure that the environment of the vacuum pump is not potentially explosive
- Make sure that the following ambient conditions are fulfilled:
  - Ambient temperature: 0 ... 40 °C (32 ... 104 °F)
  - Ambient pressure: atmosphere
  - Humidity range: 20 to 95%
  - Altitude: up to 1000 m
- Make sure that the cooling water fulfills the following requirements:
  - Temperature: 10 - 25 °C
  - Water pressure: 2 - 5 bar (relative)
  - Approximate flow rate: min. 8 l/ min for the standard version
  - Water hardness: < 5° dGH

**NOTE:** 1° (german degree = 1° dGH) = 1,78° (french degree) = 1,25 e (english degree) = 17,9 mg/kg CaCO<sub>3</sub> (american hardness)

- Make sure that the cooling water is neutral and clean
- Make sure that the cooling water outlet is unpressurised
- Make sure that the nitrogen fulfills the following requirements:
  - Overpressure: 1,5 bar
- Make sure that the ambient conditions correspond to the protection class of the motor (according to nameplate)
- Make sure that the vacuum pump is placed on or fastened to a horizontal surface
- Make sure that the vacuum pump is level
- Make sure that the vacuum pump is at least 1 m away from any wall to ensure good cooling
- Make sure that the vacuum pump is easily accessible and that the selected installation site fulfills the requirements for assembly/ dismantling
- Make sure that no temperature-sensitive parts (for example, of plastic, wood, cardboard, paper, electronic parts) come into contact with the hot surfaces of the vacuum pump
- Make sure that the installation site or assembly area is ventilated in such a way that adequate cooling of the vacuum pump is ensured





CAUTION

The surface temperature of the vacuum pump can exceed 50°C when the vacuum pump is in operation.

Danger of burns!

- Make sure that no-one can touch the vacuum pump accidentally. If necessary, attach safeguard
- Make sure that the oil sight glasses (OSG 1 & 2) are easily accessible

If oil changes are to be made on site:

- ◆ Make sure that the oil drain and oil filler are easily accessible

## Inlet connection

- Make sure that the protection that was attached to prevent penetration of particles during transport has been removed before the vacuum pump is connected to the vacuum line



CAUTION

Do not put hands into the inlet aperture.

Risk of body damage !



CAUTION

The intake of liquids or solid particles can lead to the destruction of the vacuum pump

If the sucked gas contains dusts or solid foreign bodies:

- ◆ Make sure that a filter or protective grating is installed at the extraction point
- Make sure that the nominal diameter of the intake line is at least equal to the diameter of the intake flange of the vacuum pump to prevent a drop in the performance of the vacuum pump in the case of a smaller cross-section
- Make sure that the vacuum pump is connected with leakproof lines



CAUTION

When the intake lines have been connected, make sure that the system does not leak. Leakages of dangerous substances must be prevented!

- Make sure that the intake lines are equipped with a shut-off device upstream of the intake flange so that the flow of sucked gas can be stopped
- Make sure that the intake lines do not exercise any force on the intake flange. Mount bellows if necessary
- The inlet flange has the following dimension:
  - DN 100 ISO

In the case of long intake lines the line cross-section should be larger than the intake flange to prevent a drop in the performance of the vacuum pump. If you have any doubts, contact your Busch representative.

## Discharge connection



CAUTION

Do not put hands into the outlet aperture.

Risk of body damage !

The following instructions for connection to the discharge only apply if the sucked gas is discharged by the vacuum pump into a suitable environment.

- Make sure that the protection that was attached to prevent penetration of particles during transport has been removed before the vacuum pump is connected to the vacuum line
- Make sure that the nominal diameter of the exhaust line is at least equal to the diameter of the exhaust flange of the vacuum pump to prevent a drop in the performance of the vacuum pump in the case of a smaller cross-section
- Make sure that the vacuum pump is connected with leakproof lines



CAUTION

When the discharge lines have been connected, make sure that the system does not leak. Leakages of dangerous substances must be prevented!

- Make sure that the discharge line is mounted in such a way that condensate cannot penetrate into the pump (siphon trap, gradient)
- Make sure that no shut-off devices are mounted in the discharge line
- Make sure that the discharge lines do not exercise any force on the discharge flange. Mount bellows if necessary
- The discharge flange has the following dimension:
  - DN 63 ISO

In the case of long discharge lines the line cross-section should be larger than the discharge flange to prevent a drop in the performance of the vacuum pump. If you have any doubts, contact your Busch representative.

## Cooling water connection

The cooling water is generally connected with a hose.

The cooling water outlet must be unpressurised.

Connection diameter: 3/8 NPT

## Nitrogen connection

The nitrogen is connected with a pipe (leakproof against oxygen).

Connection diameter: 1/4 NPT

## Electrical connection/ Checks

- Make sure that the regulations of the Electromagnetic Compatibility Directive 2014/30/EU as well as standard EN norms, safety directives and especially local and national regulations are observed (this is the responsibility of the manufacturer of the system into which the vacuum pump is integrated according to the EU-Declaration of Conformity)
- Make sure that the mains power supply corresponds to the data on the nameplate of the motor
- Make sure that an overload cut-out according to EN 60204-1 is provided for the motor
- Make sure that the drive of the vacuum pump is not disturbed by any electric or electromagnetic interferences. If you have any doubts, contact your Busch representative

## Installation

### Mounting

- Make sure that the "Necessary installation instructions" are followed
- Fasten or install the pump at its final installation site

## Electrical connection



### WARNING

Risk of electrocution, risk of damage.

Electrical installation must be performed by a suitably qualified electrician who knows and follows the following regulations:

- IEC 364 or CENELEC HD 384 or DIN VDE 0100,
- IEC Report 664 or DIN VDE 0110,
- VBG 4 or corresponding national regulations on accident prevention



### CAUTION

The circuit diagrams described below conform to the standard. Other circuit diagrams might be used. This depends on the particular order and the market.

Risk of damage to the motor!

Check the connection of the motor inside the terminal box according to the circuit diagram.

Motor of screw pump DS 0600 E PE is connected at factory.



### CAUTION

When connecting up the wires into the terminal box: please make sure the tightening torque of **3 Nm** is adhered to and check with a calibrated torque wrench (Nuts M6).

### Three phase motor connection

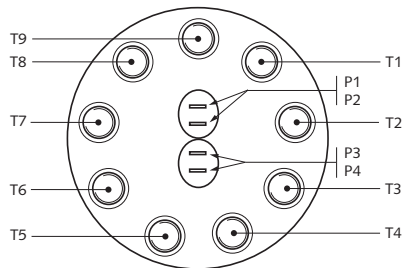

### Star-star connection (Low voltage)

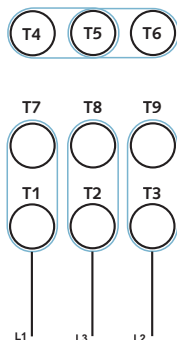

### Star connection (High voltage)

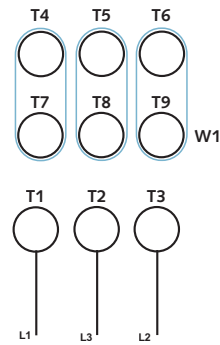

### Thermo switch connection



### Connection of supply cable to control box

- Pass the cable through cable fitting of control box
- Open the electrical board
- Unscrew the two screws of the bottom main contactor cover and remove the cover



- Unscrew completely the first connector on the main contactor
- Place the first phase wire and screw it completely, tight at 15 Nm
- Repeat the procedure for the two other phases
- Unscrew completely the ground phase screw
- Connect the ground wire to ground terminal
- Rescrew the ground phase and tight it at 15 Nm
- Remount the cover of the main contactor



### CAUTION

If the vacuum pump is operated with a motor that turns in the wrong direction, it can be destroyed, even if this is the case for only a short moment.

Make sure that the vacuum pump is connected correctly before switching it on.

- Determine rotation sense of the motor by using a measure tool or by placing a rubber plate on the inlet.
- Press the on/ off switch briefly
- Make sure that the vacuum pump draws in

If the direction of rotation has to be changed:

- ◆ Exchange two of the three feeder leads

### Equipment connections (with options)

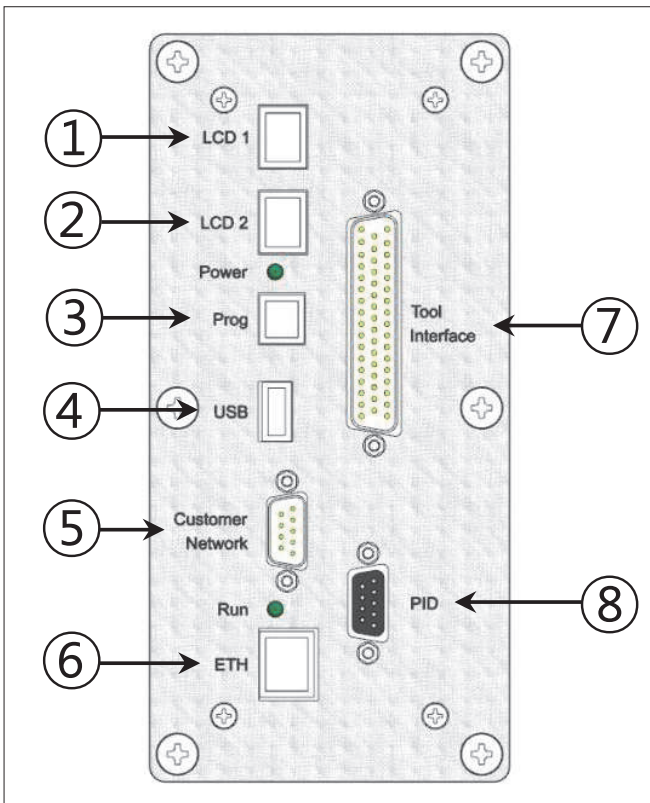

- 1 LCD serial wiring (RJ45), LCD1
- 2 LCD serial wiring (RJ45), LCD2
- 3 PC serial wiring (9 poles) (option)
- 4 USB connection
- 5 Customer Network, Communication modbus RTU RS 232
- 6 Ethernet network connection (Busch Monitoring System) (option)
- 7 Interface connection (50 poles) (option)
- 8 PID Interface (9 poles) (option)

The information concerning the use of the Busch PLC and the Busch LCD can be found in the Operation and Maintenance manual (Art-No. 0870758077).

### Connection of the lines/ pipes

- Connect the intake lines
- Connect the discharge lines
- Make sure that all caps, safeguards and similar covers are mounted
- Make sure that the inlet and outlet for the cooling air are not covered or closed and that the flow of cooling air is not impaired in any way

## Oil filling

The COBRA DS 0600 E PE vacuum pumps are generally dispatched with oil already in the vacuum pump. Before vacuum pump first startup, control the oil level. In the event of absence of one or the other of these lubricants, please carry out the filling (see the chapter "Oil types" for information on the recommended oils).

- Prepare the quantity of oil specified in the table "Oil quantity"

**NOTE:** The quantity of oil specified in the installation handbook is of informative nature only. Check the oil level with the help of the various oil sight glasses (OSG 1 & 2) on the vacuum pump.



### CAUTION

Before you change the type of oil, make sure that the new type is compatible with the old type. If necessary, flush the vacuum pump.

- Unscrew the oil filler cap (OFP)

### Oil level, pump not operating

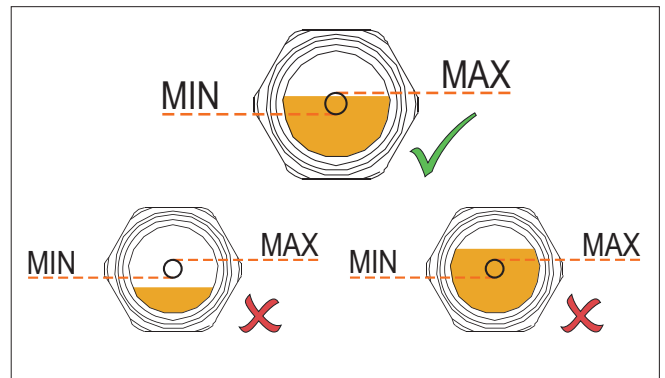

- Fill in oil
- Make sure that the oil level is in the target circle of the oil sight glasses
- Make sure that the seals of the oil filler cap are not damaged. Replace them if necessary
- Screw on the oil filler cap hermetically tight

**NOTE:** It is easier to switch on the vacuum pump with cold oil when the intake line is not closed or when the intake flange is not covered by a rubber plate.

- Start the vacuum pump

If the intake line is equipped with a shut-off device:

- ◆ Close the shut-off device

If the intake line is not equipped with a shut-off device:

- ◆ Place a rubber plate on the intake flange

- Let the vacuum pump run for a few minutes
- Stop the vacuum pump and wait a few minutes
- Make sure that the oil level still is in the target circle of the oil sight glasses

If the oil level is below the target circle level :

- ◆ Fill in more oil

If the intake line is equipped with a shut-off device:

- ◆ Open the shut-off device

If the intake line is not equipped with a shut-off device:

- ◆ Remove the rubber plate from the intake flange and connect the intake line to the intake flange



#### CAUTION

In case of a vacuum pump filled with oil, make sure that by lifting the inclination angle of the vacuum pump do not exceed 5° from the horizontal. In case of too high inclination (>5°), risk of oil leak within the work area

- Make sure before every transport using the appropriate lifting mean that the inclination of the vacuum pump is less than 5°.



#### CAUTION

The vacuum pump must remain in a horizontal position when it has been filled with oil.

## Filling in cooling liquid

The COBRA DS 0600 E PE vacuum pumps are generally dispatched with cooling liquid already in the vacuum pump. Before vacuum pump first startup, control the cooling liquid level. In the event of absence of one or the other of these lubricants, please carry out the filling (see the chapter "Cooling liquid types" for information on the recommended cooling liquids).

- Prepare the quantity of cooling liquid specified in the table "Cooling liquid quantity"

**NOTE:** The quantity of cooling liquid specified in the installation handbook is of informative nature only. Respect the procedure of filling the cooling liquid.

- Unscrew filler cap (CLF) of cooling liquid on cylinder upper plate
- Open purge valve (CLV) on cylinder upper plate and purge cap on cylinder endplate B-side
- Fill in by filler hole until cooling liquid flows by drain plug of cylinder upper plate
- Stop filling in cooling liquid
- Close the drain plug
- Fill in again by filler hole until cooling liquid flows by purge valve of cylinder upper plate
- Close the drain cock
- Screw on the filler cap for the cooling liquid again
- If liquid has run on to the outside surfaces of the vacuum pump, wipe it off
- Start the vacuum pump

If the intake line is equipped with a shut-off device:

- ◆ Close the shut-off device

If the intake line is not equipped with a shut-off device:

- ◆ Place a rubber plate on the intake flange
- Let the vacuum pump run for a few minutes
- Stop the vacuum pump and wait a few minutes
- Unscrew purge valve
- Control that cooling liquid level is just under cylinder upper plate

In case cooling liquid level is below required level:

- ◆ Fill in more cooling liquid

If the intake line is equipped with a shut-off device:

- ◆ Open the shut-off device

If the intake line is not equipped with a shut-off device:

- Remove the rubber plate from the intake flange and connect the intake line to the intake flange

## Checking the direct cooling

The flow of the cooling water is checked by the flow switch FS 2. The flow switch must be connected in such a way that switching-on leads to an alarm and stopping of the vacuum pump when the flow drops below 7 l/min.

## Saving the operating parameters

As soon as the vacuum pump is working under normal conditions after being switched on:

- Measure the working current of the motor and save it as reference value for all future maintenance and repair work

## Recommendations on operation

### Application



#### WARNING

The vacuum pump is designed for use under the conditions specified here.

**If these conditions are not met, there is a risk of damage to or total destruction of the vacuum pump and its components!**

**The vacuum pump may only be switched on under the specified conditions.**

The COBRA DS vacuum pumps are designed for use in the field of microelectronics and similar industries.

They can be used to suck gases and gas mixtures.



#### WARNING

**When using toxic, inflammable and/or explosive gases, make sure that the system corresponds in design to applicable local and national safety regulations and that all applicable safety measures are followed.**

**All product-specific safety regulations must be observed.**

Solid particles must not get into the vacuum pump. Procedural errors can result in the pump sucking in a certain quantity of liquid. If the pump has sucked in liquid, a short drying time is necessary at the end of the procedure.

The allowed maximum inlet gas temperature depends on the inlet pressure and the type of gas: the lower the inlet pressure (Pa), the higher the drawn gas temperature (T<sub>Gas</sub>) can be.

The following indicative values for air can be considered:

- Pa > 50 mbar, T<sub>Gas</sub> < 80°C
- Pa < 50 mbar, T<sub>Gas</sub> < 200°C

The vacuum pump is intended for use in a potentially non-explosive environment.

As far as temperature is concerned, the pump is suitable for continuous duty at any pressure between atmosphere and ultimate pressure.

The vacuum pump is tight down to ultimate pressure.



#### CAUTION

The surface temperature of the vacuum pump can exceed 50 °C when the vacuum pump is in operation.

Danger of burns!

The vacuum pump may not be touched when it is in operation. If touching the pump is unavoidable, wait until the surface temperature has cooled down or wear protective gloves.





#### CAUTION

The intensity of the noise of the vacuum pump is higher within a certain area of the pump.

Risk of hearing damage.

Users must wear ear protection when spending a longer period of time in the vicinity of a non-insulated vacuum pump.



#### CAUTION

The COBRA DS 0600 E PE vacuum pumps could be delivered without oil, without cooling water and without cooling liquid. Operation without oil will result in damage to the vacuum pump!

The vacuum pump must remain in a horizontal position when it has been filled with oil.



#### CAUTION

The COBRA DS 0600 E PE vacuum pumps are always delivered without oil, without cooling water and without cooling liquid.

Operation without coolants will result in damage to the vacuum pump!



#### CAUTION

The cooling water flow, which is checked by the flow switch FS 2, must be at least 8 l/min.

- Make sure that all caps, safeguards and similar covers are mounted
- Make sure that the safeguards are switched on
- Make sure that the inlet and outlet for the cooling air are not covered or closed and that the flow of cooling air is not impaired in any way
- Make sure that the system does not leak. Leakages of dangerous substances must be prevented
- Make sure that the "Necessary installation instructions" are followed and especially that adequate cooling is ensured

The following must be noted when the pump is shut down for a longer period of time:



#### CAUTION

If there is a risk of frost, all the cooling water must be drained out of the vacuum pump if the pump is shut down for a longer period of time!

- Drain the cooling liquid
  - ◆ Unscrew the filler cap for the cooling liquid
  - ◆ Drain the cooling liquid completely
  - ◆ Screw on the filler cap for the cooling liquid again
  - ◆ Collect the cooling liquid and recycle it or dispose of it according to local or national regulations
- Drain the cooling water
  - ◆ Pull off the connections for the inlet and outlet of the cooling water
  - ◆ Drain the cooling water completely
  - ◆ If necessary, drain the cooling water with the help of compressed air to prevent any risk of frost or corrosion

**NOTE:** When the pump has not been in operation for a few days or when a sticky substance has been sucked, it is possible that the two scroll rotors of the NS vacuum pump will stick to each other. Screw open the access cover to the scroll rotors. Loosen the rotors from each

other with the help of an Allan key by turning them in clockwise direction by hand.

## Switching the vacuum pump on/ off

### First start-up of the system

- Make sure that the "Necessary installation instructions" are followed
- If the system is equipped with a solenoid gate valve in the cooling water circuit:
- ◆ Open the solenoid gate valve
  - Make sure that the cooling water flow is set correctly
- The cooling water flow is factory set on 8 NI/min and can be adjusted at the regulating cock CWV. This water circuit is used to cool the motor of the NS pump. It cools also the cylinder and cylinder endplate B-side when temperature of cooling liquid is above 50°C.

- Switch on the vacuum pump
- Make sure that the system does not leak

If the system is equipped with a solenoid gate valve at the intake:

- ◆ Open the solenoid gate valve

### Switching the system off

If the system is equipped with a solenoid gate valve at the intake:

- ◆ Close the solenoid gate valve
- Switch off the vacuum pump
- Shut off the nitrogen supply
- Shut off the cooling water supply

If the system is equipped with a solenoid gate valve in the cooling water circuit:

- ◆ Close the solenoid gate valve
- Make sure that the system is currentless

## Maintenance



**DANGER**

**In case the vacuum pump has conveyed gases that have been contaminated with foreign materials that are dangerous to health, the oil and condensates will also be contaminated.**

**These foreign materials can infiltrate the pores, recesses and other internal spaces of the vacuum pump.**

**Danger to health when the vacuum pump is dismantled.**

**Danger to environment.**

**Always wear protective clothing when carrying out maintenance work.**

**Before any maintenance work, the inlet and outlet piping as well as the vacuum pump itself must be flushed with nitrogen.**



#### CAUTION

Only authorised personnel may carry out dismantling work on the vacuum pump. Before work begins, the operator of the vacuum pump must fill in a form or a "Declaration Regarding Contamination of Equipment and Components" that provides information on possible dangers and appropriate measures. If this form has not been filled in completely and signed, the vacuum pump may not be dismantled.





#### CAUTION

Before maintenance work is started, a safety area of at least 610 [mm] around the machine must be set up.



#### CAUTION

The surface temperature of the vacuum pump can exceed 50°C when the vacuum pump is in operation.

Danger of burns!

Before starting maintenance work, make sure that the vacuum pump has been switched off and that it cannot be switched on again accidentally. Follow the shutdown procedure in the section "Lock Out/ Tag Out procedure":

- stop the pump with the remote control (press on STOP button during 10s)
- press on emergency stop button
- switch off the main disconnect switch
- switch off the customer's power supply
- switch off the water and nitrogen quick connections (inlet first, then outlet)
- put the label or warning board "Maintenance processing" on or next to the pump



#### CAUTION

The oil temperature can reach a value of 90°C!

Danger of burns!

- Make sure that the oil circuit and the coolant circuit have been emptied before moving the vacuum pump
- Make sure that there are no cleaning tools in the pump anymore according to local and national regulations

Before pulling off the different connections, make sure that the intake and exhaust lines of the vacuum pump correspond to atmospheric pressure

When the maintenance work has been finished, follow the procedure "Safety Lockout procedure":

- take off the label or warning board "Maintenance processing"
- check the cooling liquid and oil levels according to the chapters "Checking the oil level" and "Checking the cooling liquid level"
- open the power box cover and check that the FDP1 thermal relay is on manual reset position
- close the cover
- switch on the main disconnect switch
- release the emergency stop button
- switch on the water and nitrogen quick connections (outlet first, then inlet)
- make sure that the "Necessary installation instructions" are followed
- start the pump with the remote control (press on START button)

## Maintenance program

**NOTE:** The maintenance intervals depend on the operating conditions. The following intervals are basic values, which can be shortened or lengthened depending on operating conditions. In especially difficult operating conditions such as, for example, a very dusty environment the maintenance intervals must be shortened considerably.

### Weekly:

- Check the oil level and the colour of the oil (see "Checking the oil")
- Check the level of the cooling liquid (see "Checking the cooling liquid")

- Check the cooling water flow (see "Checking the cooling water")
- Check the nitrogen flow (see "Checking the nitrogen")
- Inspect the vacuum pump for oil leaks - if there are leaks, repair the vacuum pump (Busch)
- Inspect the vacuum pump for leaks of cooling liquid - if there are leaks, repair the vacuum pump (Busch)
- Inspect the vacuum pump for leaks of cooling water - if there are leaks, repair the vacuum pump (Busch)

### Monthly:

In the case of operation in a dusty environment:

- ◆ Make sure that the operating room is clean and free of dust; clean if necessary
- Make sure that the vacuum pump has been switched off and that it cannot be switched on again accidentally
- Check the electrical connections
- Carry out a visual inspection of the vacuum pump

### Yearly:

- Make sure that the vacuum pump has been switched off and that it cannot be switched on again accidentally

If the intake is equipped with a sieve:

- ◆ Check the sieve at the intake and clean if necessary
- Check the measuring and safety equipment for working order

If the discharge is equipped with a sound absorber:

- ◆ Clean the sound absorber

If the discharge is equipped with a leak-protection non-return valve:

- ◆ Clean the leak-protection non-return valve
- Drain the cooling liquid (see "Draining the cooling liquid")

If the cooling water line is equipped with a filter:

- ◆ Check the filter and clean or replace if necessary
- Check the seals and replace if necessary
- Check the intake and discharge lines and clean or replace if necessary

### Every 16 000 hours of operation, at the latest after 4 years:

- Drain the oil (see "Draining the oil")
- A main inspection of the vacuum pump (Busch)

### Lock Out/ Tag Out procedure

- Stop the pump with the remote control (press on STOP button during 10s)
- Press on emergency stop button
- Switch off the main disconnect switch
- Switch off the customer's power supply
- Switch off the water and nitrogen quick connections (inlet first, then outlet)
- Put the label or warning board "Maintenance processing" on or next to the pump

### Safety Lockout procedure

- Take off the label or warning board "Maintenance processing"
- Check the cooling liquid and oil levels according to the chapters "Checking the oil level" and "Checking the cooling liquid level"
- Open the power box cover and check that the FDP1 thermal relay is on manual reset position
- Close the cover
- Switch on the main disconnect switch

- Release the emergency stop button
- Switch on the water and nitrogen quick connections (outlet first, then inlet)
- Make sure that the "Necessary installation instructions" are followed
- Start the pump with the remote control (press on START button)

## Checking the oil

### Checking the oil level

- Make sure that the vacuum pump has been switched off and that it cannot be switched on again accidentally
- Indication of the oil level on the various oil sight glasses

### Oil level, pump not operating

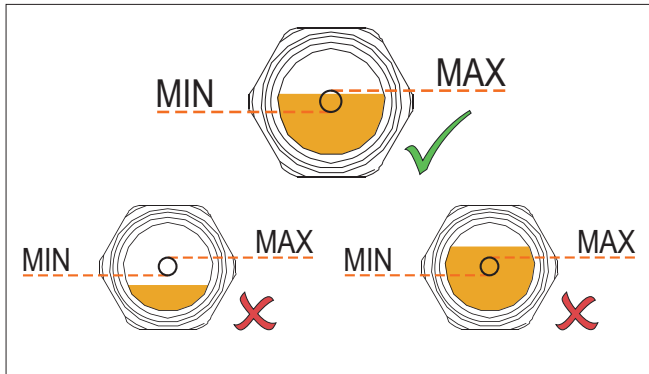

If the oil level does not reach the target circle level:

- ◆ Top up with oil (see "Refilling oil")

If the oil level exceeds the target circle level:

- ◆ Check the condensate drain
- Drain the oil (see "Draining the oil")

### Refilling oil

**NOTE:** Oil does not normally have to be refilled outside the recommended oil change intervals. A drop in the oil level indicates a fault (see "Troubleshooting").



**CAUTION**

Only fill in oil through the oil filler opening.



**CAUTION**

Danger of burns when the oil filler cap is open.

Danger of injuries when the oil filler cap is not screwed on properly.

Only unscrew the oil filler cap when the vacuum pump has been switched off.

The vacuum pump may only be switched on when the oil filler cap is properly closed and tight.

- Make sure that the vacuum pump has been switched off and that it cannot be switched on again accidentally
- Unscrew the oil filler cap (OFF)
- Fill in oil up to the target circle of the oil sight glasses
- Make sure that the oil level is in the target circle of the oil sight glasses
- Make sure that the seals of the filler cap are not damaged and that they sit properly. Replace them if necessary
- Screw on the filler cap again

## Checking the colour of the oil

**NOTE:** The oil must be clear and transparent. A permanent milky colour is an indication for contamination by foreign bodies. A dark colour is an indication for oil that has been chemically altered or contaminated by foreign bodies.



**WARNING**

Dark colored oil may indicate a hazardous pump condition which could cause personal injury.

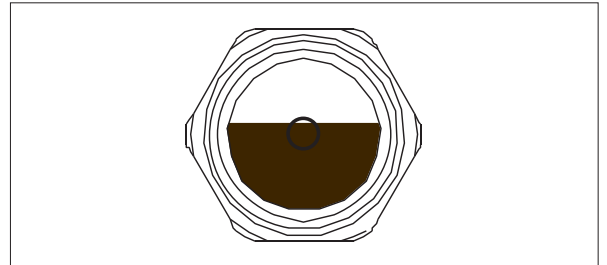

If dark oil similar to the example shown is observed, you have to contact the Busch Customer Service without delay.

## Oil change



**DANGER**

If the vacuum pump has pumped gases that were contaminated with foreign bodies that are hazardous to health, the oil is also contaminated with these foreign bodies.

There is a health hazard when changing contaminated oil.

There is also a danger to the environment.

Wear protective clothing when replacing contaminated oil.

Contaminated oil must be treated specially and must be disposed of according to applicable regulations.

## Draining used oil

**NOTE:** After switching off the vacuum pump at normal operating temperature wait no more than 20 minutes before the oil is drained.

- Make sure that the vacuum pump is switched off and cannot accidentally be switched on again
- Make sure that the vacuum pump is vented to atmospheric pressure
- Put a drain tray underneath the oil drain plugs (ODP)
- Unscrew the oil drain plugs (ODP)
- Carefully remove the drain plugs
- Drain the oil
- Because of wear and tear on the seal replace the current drain plugs with new ones

When the oil flow has stopped:

- Close the oil drain plugs (ODP)
- Switch on the vacuum pump for a few seconds
- Make sure that the vacuum pump is switched off and cannot accidentally be switched on again
- Carefully remove the oil drain plugs again and drain any remaining oil
- Check that no metal swarf sticks to the magnet of the drain plug, clean if necessary
- Refit the oil drain plugs and tighten up

- Dispose of the used oil in compliance with applicable regulations



#### CAUTION

Because the ends of the drain plugs are magnetic, metal swarf can stick to them. Always clean away this swarf when removing the drain plugs.

Because of wear and tear of the seals, it is recommended to replace the drain plugs whenever the oil is changed.

### Filling in new oil

- Prepare the quantity of oil needed (see "Oil type/quantity")



#### WARNING

The use of chemically contaminated or polluted oil can lead to hazardous pump conditions which could cause personal injury.

**NOTE:** The quantity of oil specified in the installation handbook is of informative nature only. Check the oil level with the help of the various oil sight glasses on the vacuum pump.

- Make sure that the drain plugs have been fitted properly and that they do not leak



#### CAUTION

Only fill in oil through the oil filler opening.

- Unscrew the oil filler cap (OFF)

### Oil level, pump not operating

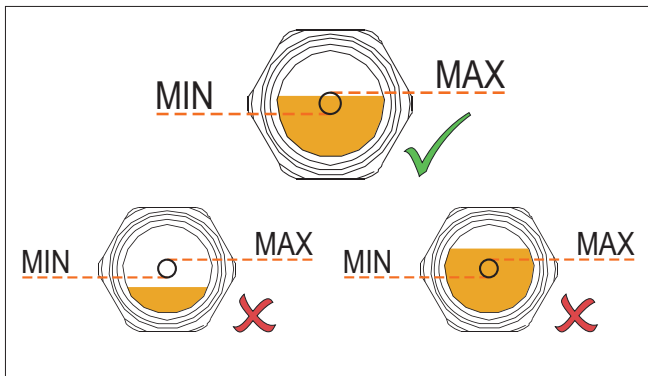

- Fill in oil up to the target circle of the oil sight glasses
- Make sure that the oil level is in the target circle of the oil sight glasses
- Make sure that the seals of the filler cap are not damaged and that they sit properly. Replace them if necessary
- Screw on the filler cap again

## Checking the cooling liquid

### Checking the level of the cooling liquid

- Make sure that the vacuum pump has been switched off and that it cannot be switched on again accidentally
- Check the level of the cooling liquid.
  - ◆ Unscrew purge valve on cylinder upper plate.

Cooling liquid level should be just under the plate.

If the level is below:

- ◆ Top up with cooling liquid (see "Refilling cooling liquid")

## Refilling cooling liquid

**NOTE:** Cooling liquid does not normally have to be refilled outside the recommended change intervals. A drop in the level of the liquid indicates a fault (see "Troubleshooting").

- Make sure that the vacuum pump has been switched off and that it cannot be switched on again accidentally
- Unscrew the filler cap (CLF) for the cooling liquid
- Open purge valve (CLV) on cylinder upper plate and drain plug on cylinder endplate B-side
- Fill in by filler hole until cooling liquid flows by drain plug of cylinder upper plate
- Stop fill in
- Close the drain plug
- Fill in again by filler hole until cooling liquid flows by purge valve of cylinder upper plate
- Close the drain clock
- Screw on the cooling liquid filler cap again
- If liquid has run on to the outside surfaces of the vacuum pump, wipe it off

## Draining the cooling liquid

- Make sure that the vacuum pump has been switched off and that it cannot be switched on again accidentally
- Make sure that the vacuum pump has adjusted to atmospheric pressure
- Place a container under the drain plug (CLD) for the cooling liquid
- Unscrew purge valve on cylinder upper plate
- Unscrew drain plug on plate B-side
- Unscrew drain plug of cooling liquid
- Drain the cooling liquid

When cooling liquid stops running out:

- Close the drain plug for the cooling liquid
- Screw purge valve and drain plug
- Switch on the vacuum pump and let it run for a few seconds
- Make sure that the vacuum pump has been switched off and that it cannot be switched on again accidentally
- Unscrew again purge valve (CLV) on cylinder upper plate
- Unscrew again purge valve (CLV) on plate B-side
- Unscrew the drain plug for the cooling liquid again and drain the remaining liquid
- Make sure that the seal of the drain plug is not damaged and that it sits properly. Replace it if necessary
- Screw on the drain plug again
- Screw purge valve and drain plug
- Dispose of the used cooling liquid according to applicable environmental protection regulations

## Filling in new cooling liquid

- Prepare the quantity of cooling liquid needed (see "Cooling liquid type/quantity")

**NOTE:** The quantity of cooling liquid specified is of informative nature only. Respect the procedure of filling the cooling liquid.

- Make sure that the drain plug sits properly and does not leak
- Unscrew purge valve on cylinder upper plate
- Unscrew drain plug on plate B-side
- Unscrew the filler cap for the cooling liquid
- Fill in by filler hole until cooling liquid flows by drain plug of cylinder upper plate

- Stop fill in
- Close the drain plug
- Fill in again by filler hole until cooling liquid flows by purge valve of cylinder upper plate
- Close the drain clock
- Make sure that the seal of the filler cap are not damaged and that they sit properly. Replace them if necessary
- Screw on the filler cap again
- Wipe cooling liquid that may have run on outside surfaces of vacuum pump

## Checking the cooling water

### Checking the cooling water flow

- Check the cooling water flow regularly

If the flow drops, check for leaks

- ◆ Make sure that the specifications of the cooling water are followed

## Checking the nitrogen

### Checking the nitrogen flow

- Check the nitrogen flow regularly

If the flow drops, check for leaks

- ◆ Make sure that the specifications of the nitrogen are followed

## Checking the current consumption

- Check the current intensity of the motor

An increased intensity is an indication for a fault (see "Troubleshooting")

## Checking the sound absorber (accessory)

- Make sure that the condensate does not collect at the exhaust of the vacuum pump
- Drain the condensate at the drain opening and collect it in a container
- Dispose of the condensate according to applicable environmental protection regulations
- Check the sound absorber regularly and clean it if necessary

## Checking the leak-protection non-return valve (accessory)

- Check the leak-protection non-return valve regularly and clean it if necessary



CAUTION

Wear protective clothing when carrying out maintenance work on the sound absorber and leak-protection non-return valve.

There could still be residues of contamination.

# Overhaul



CAUTION

Inappropriate maintenance work on the vacuum pump can damage the pump.

Danger of explosion!

If requirements are not met, the vacuum pump may not be switched on!

Should work exceed the dismantling work described in this handbook, it may only be carried out by authorised persons.



DANGER

If the vacuum pump has pumped gases that were contaminated with foreign bodies that are hazardous to health, the oil and condensate are also contaminated with these foreign bodies.

These foreign bodies can penetrate into pores, openings and other internal parts of the vacuum pump.

There is a health hazard when dismantling the vacuum pump.

There is also a danger to the environment.

Prior to shipping, the vacuum pump must imperatively be decontaminated and the degree of contamination must be documented in a declaration of decontamination ("Declaration of Decontamination"), which can be downloaded from [www.buschvacuum.com](http://www.buschvacuum.com).

Busch service will only accept vacuum pumps that come with a completely filled in and legally binding signed form.

## Removal from service

### Temporary removal from service

Before disconnecting the intake and exhaust lines and switching off the cooling water and nitrogen lines, make sure that the lines have adjusted to atmospheric pressure

## Recommissioning



CAUTION

If the vacuum pump was switched off for a longer period of time, the rotors of the COBRA NS vacuum pump can be jammed.

Turn the scroll rotors by hand.

- Make sure that the various protective elements, stoppers or adhesive tapes have been removed
- Switch on the vacuum pump by following the procedure described in the chapter "Installation and start-up"

## Dismantling and disposal



If the vacuum pump has pumped gases that were contaminated with foreign bodies that are hazardous to health, the oil and condensate are also contaminated with these foreign bodies.

These foreign bodies can penetrate into pores, openings and other internal parts of the vacuum pump.

There is a health hazard when dismantling the vacuum pump.

There is also a danger to the environment.

Protective clothing must be worn when dismantling the vacuum pump.

Prior to shipping, the vacuum pump must imperatively be decontaminated and the degree of contamination must be documented in a declaration of decontamination ("Declaration of Decontamination"), which can be downloaded from [www.buschvacuum.com](http://www.buschvacuum.com).

Dispose of the used oil and condensate according to applicable environmental protection regulations.

When the product has reached the end of its lifetime:

- decontaminate the vacuum pump



Only authorised personnel may carry out dismantling work on the vacuum pump. Before work begins, the operator of the vacuum pump must fill in a form or a "Declaration of Decontamination" that provides information on possible dangers and appropriate measures.

If this form has not been filled in completely and signed, the vacuum pump may not be dismantled.

- drain the oil
  - ◆ dispose of the oil according to local environmental protection regulations
- drain the cooling liquid
  - ◆ dispose of the cooling liquid according to local environmental protection regulations
- begin dismantling the vacuum pump



Wear protective clothing when carrying out dismantling work.

- ◆ dispose of the vacuum pump as scrap metal
- dispose of the individual parts of the machine according to local regulations

A lithium battery is present inside the PLC:

- eliminate the lithium battery according to local and national regulations in place, relating to environment



# Oil type/ quantity

## Oil type

- Make sure that the oil type corresponds to specification:
- Busch YLC 250 B, Art. No. 0831 131 400 (0,5 l  $\cong$  1 kg)



**WARNING**

The use of chemically contaminated or polluted oil can lead to hazardous pump conditions which could cause personal injury.

## Oil quantity

The quantity of oil specified in the following table is of informative nature only. Check the oil level with the help of the various oil sight glasses on the vacuum pump.

Quantity [Liter]	Screw vacuum pump NS	
	Motor side (A)	Inlet side (B)
DS 0600 E PE	0,8	0,8

# Cooling liquid type/ quantity

## Cooling liquid type

- Make sure that the cooling liquid type corresponds to specifications :

Specifications	Zitrec M-25 (ready-to-use)	
	20 litres can	5 litres can
	part no. 0831 238 761	part no. 0831 563 469

## Cooling liquid quantity

The quantity of cooling liquid specified in this instructions manual is of informative nature only. Respect the procedure of filling the cooling liquid.

Quantity	Zitrec M-25 (already mixed ready-to-use)
DS 0600 E PE	approx. 26 litres



### CAUTION

The proportion of pure glycol and water for the cooling liquid corresponds to a percentage of 40% pure glycol and 60% water. It is therefore not necessary to prepare the mix before use. But when using pure glycol, it is imperative to prepare the mix prior to filling the pump and to respect this proportion.

# Technical data

Technical data			DS 0600 E PE
Nominal suction capacity	60 Hz	m <sup>3</sup> /h (cfm)	610 (359)
Ultimate pressure	60 Hz	Torr mbar	7,5x 10 <sup>-4</sup> 1,0 x 10 <sup>-3</sup>
Nominal motor rating	60 Hz	kW	15,0
Electric power capacity at ultimate pressure	60 Hz	kW	3,3
Nominal motor speed	60 Hz	min <sup>-1</sup>	3600
Noise level (EN ISO 2151)	60 Hz	dB(A)	68
Ambient temperature		°C (°F)	0-40 (32-104)
Maximal counter pressure	Discharge	bar	0,2
Cooling water requirement		l/ min	min. 8.0
Cooling water pressure		bar/ ΔP	2 - 5
Cooling water temperature		°C	10 - 25
Nitrogen overpressure		bar	4,0 (CDA)
Weight	approx.	kg	745

---

# EU Declaration of Conformity

This Declaration of Conformity and the CE-mark affixed to the nameplate are valid for the machine within the Busch scope of delivery. This Declaration of Conformity is issued under the sole responsibility of the manufacturer. When this machine is integrated into a superordinate machinery the manufacturer of the superordinate machinery (this can be the operating company, too) must conduct the conformity assessment process for the superordinate machine or plant, issue the Declaration of Conformity for it and affix the CE-mark.

The manufacturer

**Busch Manufacturing Korea, Ltd.**  
189-51, Soicheon-ro, Majang-myun  
Icheon-si, Gyunggi-do, 467-813  
Republic of Korea

declares that the machine(s): **COBRA DS 0600 E PE**

fulfil(s) all the relevant provisions from European directives:

- 'Machinery' 2006/42/EC
- 'Electromagnetic Compatibility' 2014/30/EU
- 'RoHS' 2011/65/EU Restriction of the use of certain hazardous substances in electrical and electronic equipment (incl. all related applicable amendments)

and comply(-ies) with the following designated standards that have been used to fulfil those provisions:

Standard	Title of the Standard
EN ISO 12100 : 2010	Safety of machinery - Basic concepts, general principles of design
EN ISO 13857 : 2019	Safety of machinery - Safety distances to prevent hazard zones being reached by the upper and lower limbs
EN 1012-1 : 2010 EN 1012-2 : 1996 + A1 : 2009	Compressors and vacuum pumps - Safety requirements - Part 1 and Part 2
EN ISO 2151 : 2008	Acoustics - Noise test code for compressors and vacuum pumps - Engineering method (grade 2)
EN 60204-1 : 2018	Safety of machinery - Electrical equipment of machines - Part 1: General requirements
EN IEC 61000-6-2 : 2019	Electromagnetic compatibility (EMC) - Generic standards. Immunity for industrial environments
EN IEC 61000-6-4 : 2019	Electromagnetic compatibility (EMC) - Generic standards. Emission standard for industrial environments
EN ISO 13849-1 : 2015 <sup>(1)</sup>	Safety of machinery - Safety-related parts of control systems - Part 1: General principles for design

<sup>(1)</sup> In case control systems are integrated.

Legal person authorized to compile the technical file  
and authorized representative in the EU  
(if the manufacturer is not located in the EU):

Busch Dienste GmbH  
Schauinslandstr. 1  
DE-79689 Maulburg

Icheon-si, 14.05.2021



**Seung-hwa Yoo, General Director**

# UK Declaration of Conformity

This Declaration of Conformity and the UKCA-mark affixed to the nameplate are valid for the machine within the Busch scope of delivery. This Declaration of Conformity is issued under the sole responsibility of the manufacturer. When this machine is integrated into a superordinate machinery the manufacturer of the superordinate machinery (this can be the operating company, too) must conduct the conformity assessment process for the superordinate machine or plant, issue the Declaration of Conformity for it and affix the UKCA-mark.

The manufacturer

**Busch Manufacturing Korea, Ltd.**  
189-51, Soicheon-ro, Majang-myun  
Icheon-si, Gyunggi-do, 467-813  
Republic of Korea

declares that the machine(s): **COBRA DS 0600 E PE**

fulfil(s) all the relevant provisions from UK legislations:

- Supply of Machinery (Safety) Regulations 2008
- Electromagnetic Compatibility Regulations 2016
- Restriction of the use of certain hazardous substances in electrical and electronic equipment Regulations 2012

and comply(-ies) with the following designated standards that have been used to fulfil those provisions:

Standard	Title of the Standard
BS EN ISO 12100 : 2010	Safety of machinery. Basic concepts, general principles of design. Risk assessment and risk reduction.
BS EN ISO 13857 : 2019	Safety of machinery - Safety distances to prevent hazard zones being reached by the upper and lower limbs.
BS EN 1012-1 : 2010 BS EN 1012-2 : 1996 + A1 : 2009	Compressors and vacuum pumps. Safety requirements. Air compressors and vacuum pumps.
BS EN ISO 2151 : 2008	Acoustics - Noise test code for compressors and vacuum pumps - Engineering method (grade 2)
BS EN 60204-1 : 2018	Safety of machinery. Electrical equipment of machines. General requirements.
BS EN IEC 61000-6-2 : 2019	Electromagnetic compatibility (EMC) - Generic standards. Immunity standard for industrial environments.
BS EN IEC 61000-6-4 : 2019	Electromagnetic compatibility (EMC) - Generic standards. Emission standard for industrial environments.
BS EN ISO 13849-1 : 2015 <sup>(1)</sup>	Safety of machinery. Safety-related parts of control systems. General principles for design.

<sup>(1)</sup> In case control systems are integrated.

Legal person authorized to compile the technical file  
and importer in the UK  
(if the manufacturer is not located in the UK):

Busch (UK) Ltd  
30 Hortonwood  
Telford - UK

Icheon-si, 14.05.2021



**Seung-hwa Yoo, General Director**



# Busch

## Vacuum Solutions

We shape vacuum for you.

### Argentina

info@busch.com.ar

### Australia

sales@busch.com.au

### Austria

busch@busch.at

### Bangladesh

sales@busch.com.bd

### Belgium

info@busch.be

### Brazil

vendas@buschdobrasil.com.br

### Canada

info@busch.ca

### Chile

info@busch.cl

### China

info@busch-china.com

### Colombia

info@buschvacuum.co

### Czech Republic

info@buschvacuum.cz

### Denmark

info@busch.dk

### Finland

info@busch.fi

### France

busch@busch.fr

### Germany

info@busch.de

### Hungary

busch@buschvacuum.hu

### India

sales@buschindia.com

### Ireland

sales@busch.ie

### Israel

service\_sales@busch.co.il

### Italy

info@busch.it

### Japan

info@busch.co.jp

### Korea

busch@busch.co.kr

### Malaysia

busch@busch.com.my

### Mexico

info@busch.com.mx

### Netherlands

info@busch.nl

### New Zealand

sales@busch.co.nz

### Norway

post@busch.no

### Peru

info@busch.com.pe

### Poland

busch@busch.com.pl

### Portugal

busch@busch.pt

### Romania

office@buschromania.ro

### Russia

info@busch.ru

### Singapore

sales@busch.com.sg

### South Africa

info@busch.co.za

### Spain

contacto@buschiberica.es

### Sweden

info@busch.se

### Switzerland

info@buschag.ch

### Taiwan

service@busch.com.tw

### Thailand

info@busch.co.th

### Turkey

vakutek@ttmail.com

### United Arab Emirates

sales@busch.ae

### United Kingdom

sales@busch.co.uk

### USA

info@buschusa.com