

# COBRA NC 0500 B

Dry screw vacuum pumps



VACUUM SOLUTIONS



## High performance

Advanced screw design, patented self-balancing screws, specially designed for vacuum packaging

## Efficient

Low cost of ownership, minimal maintenance, long service intervals, high uptime, efficient water cooling

## Easy cleaning

Smooth surface design, can be cleaned using steam jets and conventional detergents

# COBRA NC 0500 B

Dry screw vacuum pumps



VACUUM SOLUTIONS

Dimensional drawing

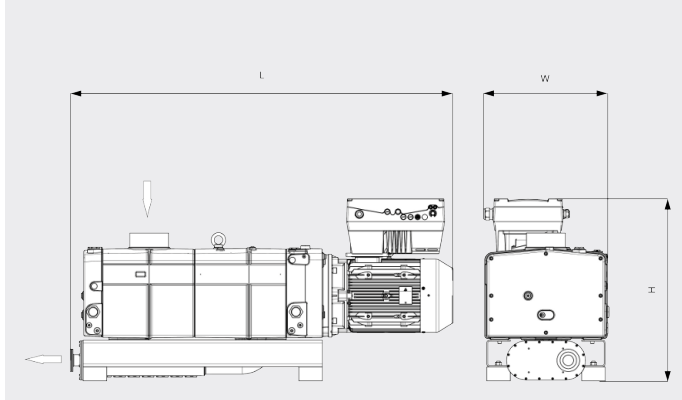

Pumping speed

Air at 70°F. Tolerance:  $\pm 10\%$

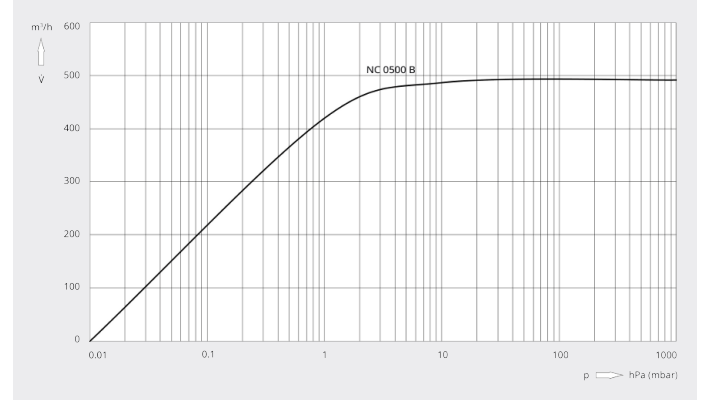

COBRA NC 0500 B	
Nominal pumping speed	288.4 ACFM
Ultimate pressure	0.0075 TORR
Nominal motor rating	12.1 HP
Nominal motor speed	2930 RPM
Operating voltage	190-210 / 380-420 V
Noise level (ISO 2151)	69 dB(A)
Weight approx.	1012 Lbs.
Dimensions (L x W x H)	45.8 x 19.1 x 21.9 inches
Gas inlet / outlet	G2" / G1½"

## DO YOU WANT TO KNOW MORE?

Get in touch with us directly!  
[info@buschusa.com](mailto:info@buschusa.com) or +1 757 463 7800



CONTACT FORM



CALL NOW