

# DOLPHIN LG 0890/1200 A

Liquid ring vacuum pumps



VACUUM SOLUTIONS



## Robust

Proven technology, reliable operation, extremely high vapor and particle tolerance, specially designed for challenging environments like mining, power plants, sugar production, pulp and paper industry, steel production etc.

## High performance

High-capacity, high pumping speeds

## Flexible

Modular design, choice of cast iron (EN-GJL-200) housing with ductile cast iron impeller or all 316 grade corrosion-free stainless steel material, operating fluids other than water possible, operation as compressor possible

### Accessories

- Motorized pumpsets, with gearbox or V-belt drive system, mounted on sturdy steel base frames
- Partial or total recirculation systems
- Cavitation protection
- Gas ejector
- Non-return valves
- Vacuum relief valves

# DOLPHIN LG 0890/1200 A

Liquid ring vacuum pumps



VACUUM SOLUTIONS

Dimensional drawing

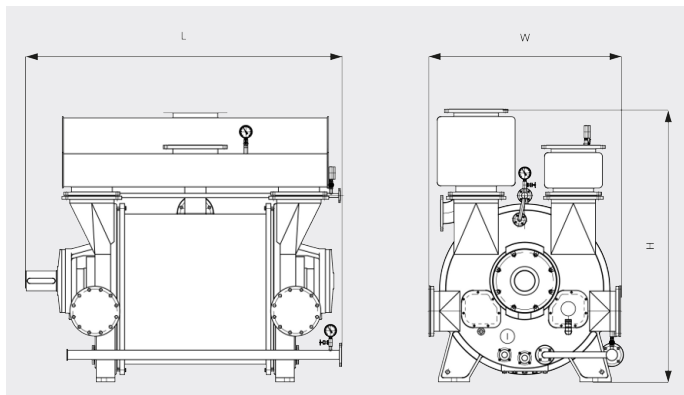

Pumping speed

Air at 20°C. Tolerance: ± 10%

— 50 Hz    ..... 60 Hz

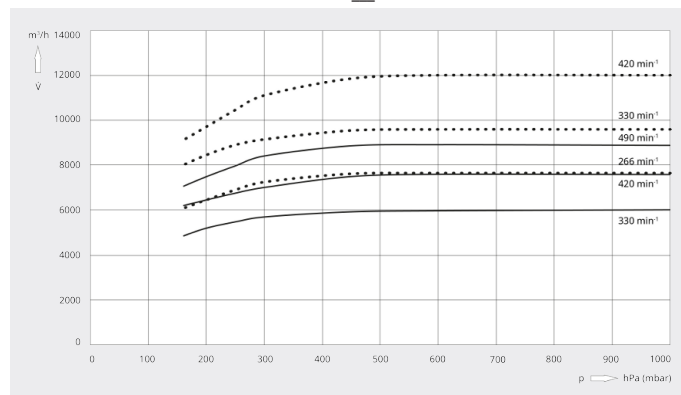

	DOLPHIN LG 0890 A	DOLPHIN LG 1200 A
Nominal pumping speed	5237.0 ACFM	7062.0 ACFM
Ultimate pressure	120 TORR	120 TORR
Nominal motor rating	300.0 HP	400.0 HP
Nominal motor speed	330 – 490 RPM	266 – 420 RPM
Noise level (ISO 2151)	< 85 dB(A)	< 85 dB(A)
Weight approx.	8536 Lbs.	12672 Lbs.
Dimensions (L x W x H)	93.3 x 52.4 x 73.4 inches	98.4 x 61 x 85 inches
Gas inlet / outlet	DN 300 PN 10 / DN 300 PN 10	DN 350 PN 10 / DN 350 PN 10

## DO YOU WANT TO KNOW MORE?

Get in touch with us directly!  
[info@buschusa.com](mailto:info@buschusa.com) or +1 757 463 7800



CONTACT FORM



CALL NOW