

# DOLPHIN LM 0100-0270 A

Liquid ring vacuum pumps and compressors



VACUUM SOLUTIONS



## Robust

Proven technology, durable single-stage construction, corrosion-free stainless steel impeller, direct flange-mounted motor, no base frame required, integrated flow channel

## Reliable

Extremely high vapor and particle tolerance, optimized gas flow

## Flexible

Choice of cast iron (EN-GJL-200) or 316 grade stainless steel material housings, ATEX-certified version available (Cat 1(i/o) IIC T4), operating fluids other than water possible

# DOLPHIN LM 0100-0270 A

Liquid ring vacuum pumps and compressors



VACUUM SOLUTIONS

Dimensional drawing

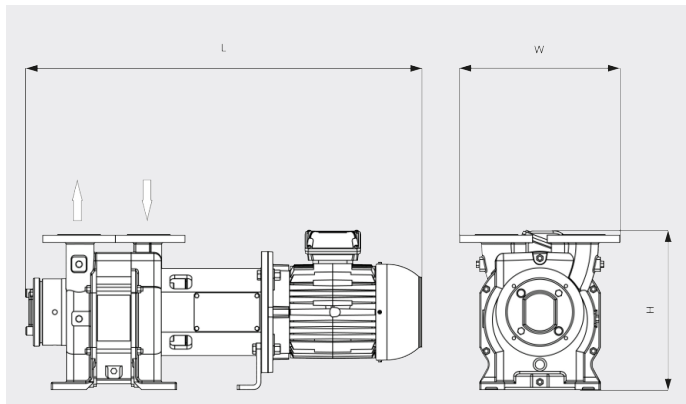

Pumping speed

Dry air at 70 °F. Operating fluid water 60°F. Tolerance: - 10%, in accordance with HEI and Pneurop 6612

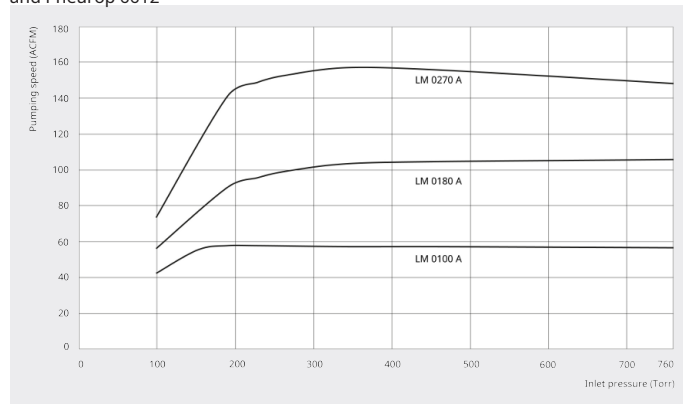

	DOLPHIN LM 0100 A	DOLPHIN LM 0180 A	DOLPHIN LM 0270 A
<b>Nominal pumping speed</b>	58.0 ACFM	106.0 ACFM	157.0 ACFM
<b>Ultimate pressure</b>	100 TORR	100 TORR	100 TORR
<b>Nominal motor rating</b>	5.0 HP	7.5 HP	10.0 HP
<b>Nominal motor speed</b>	1800 RPM	1800 RPM	1800 RPM
<b>Noise level (ISO 2151)</b>	71 dB(A)	71 dB(A)	71 dB(A)
<b>Weight approx.</b>	275 Lbs.	349 Lbs.	374 Lbs.
<b>Dimensions (L x W x H)</b>	36 x 13.4 x 12.6 inches	39.2 x 14.4 x 12.6 inches	42.6 x 14.3 x 42.6 inches
<b>Gas inlet / outlet</b>	DN 40 PN 10 / ANSI 1½" / 150 lbs / JIS 40 10K / DN 40 PN 10 / ANSI 1½" / 150 lbs / JIS 40 10K	DN 40 PN 10 / ANSI 1½" / 150 lbs / JIS 40 10K / DN 40 PN 10 / ANSI 1½" / 150 lbs / JIS 40 10K	DN 40 PN 10 / ANSI 1½" / 150 lbs / JIS 40 10K / DN 40 PN 10 / ANSI 1½" / 150 lbs / JIS 40 10K

## DO YOU WANT TO KNOW MORE?

Get in touch with us directly!  
[info@buschusa.com](mailto:info@buschusa.com) or +1 757 463 7800



CONTACT FORM



CALL NOW