

DOLPHIN LM 0530/0800 A

Liquid ring vacuum pumps and compressors



VACUUM SOLUTIONS



Robust

Proven technology, durable single-stage construction, corrosion-free stainless steel impeller, direct flange-mounted motor, no base frame required, integrated flow channel

Reliable

Extremely high vapor and particle tolerance, optimized gas flow

Flexible

Choice of cast iron (EN-GJL-200) or 316 grade stainless steel material housings, ATEX-certified version available (Cat 1(i/o) IIC T4), operating fluids other than water possible

DOLPHIN LM 0530/0800 A

Liquid ring vacuum pumps and compressors



VACUUM SOLUTIONS

Dimensional drawing

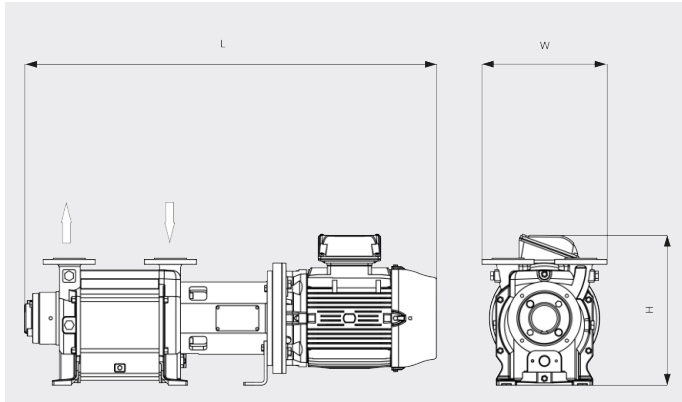

Pumping speed

Dry air at 70 °F. Operating fluid water 60°F. Tolerance: - 10%, in accordance with HEI and Pneurop 6612

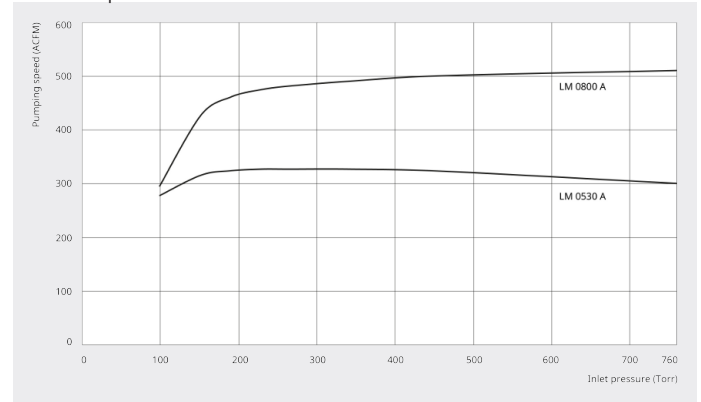

	DOLPHIN LM 0530 A	DOLPHIN LM 0800 A
Nominal pumping speed	327.0 ACFM	510.0 ACFM
Ultimate pressure	100 TORR	100 TORR
Nominal motor rating	15.0 HP	30.0 HP
Nominal motor speed	1800 RPM	1800 RPM
Noise level (ISO 2151)	73 dB(A)	76 dB(A)
Weight approx.	722 Lbs.	924 Lbs.
Dimensions (L x W x H)	51.2 x 17.8 x 15.8 inches	59.7 x 21.5 x 17.7 inches
Gas inlet / outlet	DN 50 PN 10 / ANSI 2" 150 lbs / JIS 50 10K / DN 50 PN 10 / ANSI 2" 150 lbs / JIS 50 10K	DN 65 PN 10 / ANSI 2½" 150 lbs / JIS 65 10K / DN 65 PN 10 / ANSI 2½" 150 lbs / JIS 65 10K

DO YOU WANT TO KNOW MORE?

Get in touch with us directly!
info@buschusa.com or +1 757 463 7800



CONTACT FORM



CALL NOW