

# DOLPHIN LN 3001/3002 A (Former NSB SB 1.25/2.25)

Liquid ring compressors

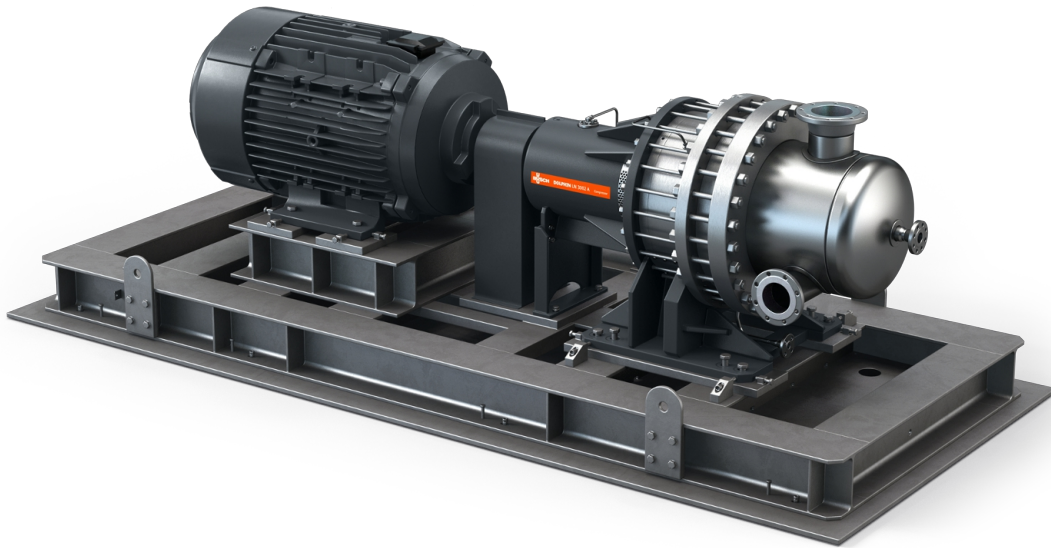

VACUUM SOLUTIONS



## Robust

API standard, ATEX-certified, test run without operating fluids possible, extremely high vapor and particle tolerance

## Easy servicing

Quick replacement of bearings and mechanical seals, no impeller adjustment needed, cleaning in place (CIP) with hot steam possible

## Simple operation

Direct start function under full discharge pressure, reaches full performance after ten seconds

# DOLPHIN LN 3001/3002 A (Former NSB SB 1.25/2.25)

Liquid ring compressors



VACUUM SOLUTIONS

Dimensional drawing

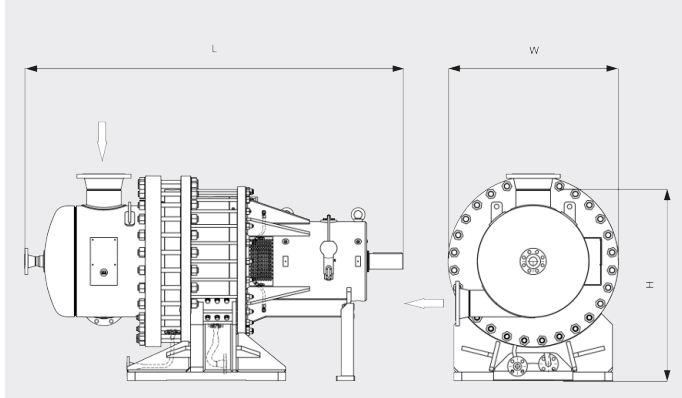

Pumping speed

Air at 70°F. Operating fluid water 59°F. Tolerance: ± 10%

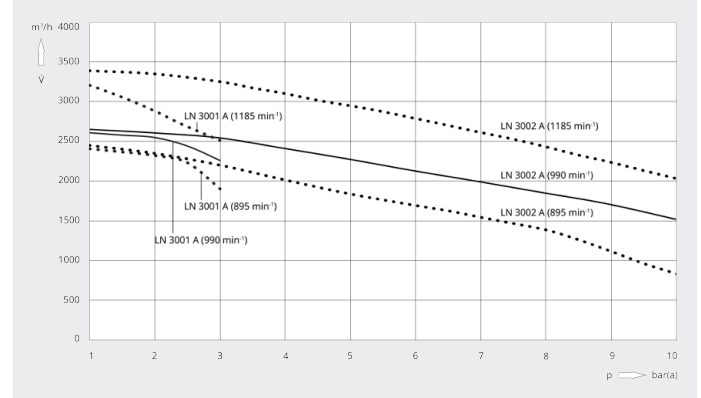

	DOLPHIN LN 3001 A	DOLPHIN LN 3002 A Preliminary
Volume flow	1589.0 ACFM	1883.2 ACFM
Overpressure	43.5 PSIA	145.1 PSIA
Nominal motor rating	500.0 HP	1100.0 HP
Nominal motor speed	1185 RPM	1185 RPM
Noise level (ISO 2151)	88 dB(A)	90 dB(A)
Max. temperature of inlet gas stream	194 °F	194 °F
Weight approx.	7920 Lbs.	8184 Lbs.
Dimensions (L x W x H)	90 x 42.3 x 51.2 inches	93.9 x 42.3 x 51.2 inches
Gas inlet / outlet	DN 200 PN 16 / DN 150 PN 16	DN 200 PN 16 / DN 150 PN 16

## DO YOU WANT TO KNOW MORE?

Get in touch with us directly!  
[info@buschusa.com](mailto:info@buschusa.com) or +1 757 463 7800



CONTACT FORM



CALL NOW