

DOLPHIN LR 0700/1190 A

Liquid ring vacuum pumps



VACUUM SOLUTIONS



Robust

Proven technology, reliable operation, extremely high vapor and particle tolerance, specially designed for challenging environments like mining, power plants, sugar production, pulp and paper industry, steel production etc.

High performance

High-capacity, high pumping speeds

Flexible

Modular design, choice of cast iron (EN-GJL-200) housing with ductile cast iron impeller or all 304 grade, or 316L grade corrosion-free stainless steel material, operating fluids other than water possible, operation as compressor possible

Accessories

- Motorized pumpsets, with gearbox or V-belt drive system, mounted on sturdy steel base frames
- Partial or total recirculation systems
- Cavitation protection
- Gas ejector
- Non-return valves
- Vacuum relief valves

DOLPHIN LR 0700/1190 A

Liquid ring vacuum pumps



VACUUM SOLUTIONS

Dimensional drawing

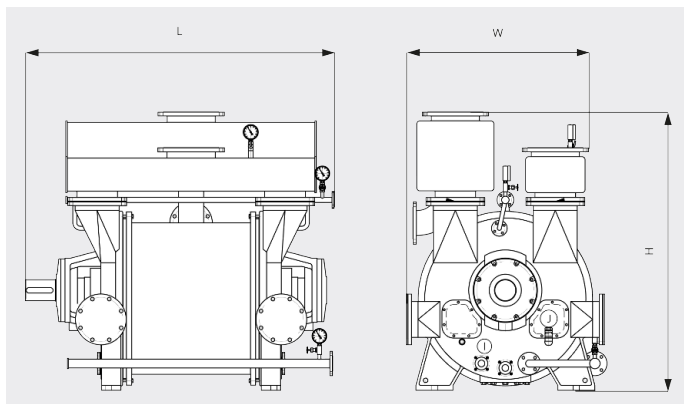

Pumping speed

Air at 20°C. Tolerance: ± 10%

— 50 Hz 60 Hz

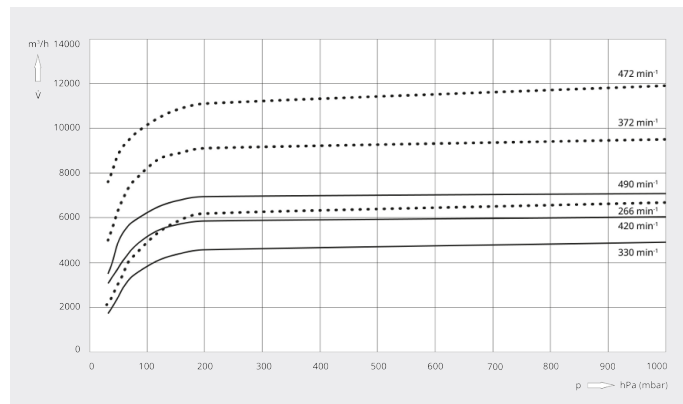

	DOLPHIN LR 0700 A	DOLPHIN LR 1190 A
Nominal pumping speed	4119.5 ACFM	7003.2 ACFM
Ultimate pressure	25 TORR	25 TORR
Nominal motor rating	250.0 HP	400.0 HP
Nominal motor speed	330 - 490 RPM	266 - 472 RPM
Noise level (ISO 2151)	< 85 dB(A)	< 85 dB(A)
Weight approx.	8250 Lbs.	11858 Lbs.
Dimensions (L x W x H)	79.5 x 53.1 x 73.4 inches	88.9 x 61 x 85 inches
Gas inlet / outlet	12" ANSI / 12" ANSI	14" ANSI / 14" ANSI

DO YOU WANT TO KNOW MORE?

Get in touch with us directly!
info@buschusa.com or +1 757 463 7800



CONTACT FORM



CALL NOW