

# DOLPHIN LR 1560/2200 A

Liquid ring vacuum pumps



VACUUM SOLUTIONS



## Robust

Proven technology, reliable operation, extremely high vapor and particle tolerance, specially designed for challenging environments like mining, power plants, sugar production, pulp and paper industry, steel production etc.

## High performance

High-capacity, high pumping speeds

## Flexible

Modular design, choice of cast iron (EN-GJL-200) housing with ductile cast iron impeller or all 304 grade, or 316L grade corrosion-free stainless steel material, operating fluids other than water possible, operation as compressor possible

### Accessories

- Motorized pumpsets, with gearbox or V-belt drive system, mounted on sturdy steel base frames
- Partial or total recirculation systems
- Cavitation protection
- Gas ejector
- Non-return valves
- Vacuum relief valves

# DOLPHIN LR 1560/2200 A

Liquid ring vacuum pumps



VACUUM SOLUTIONS

Dimensional drawing

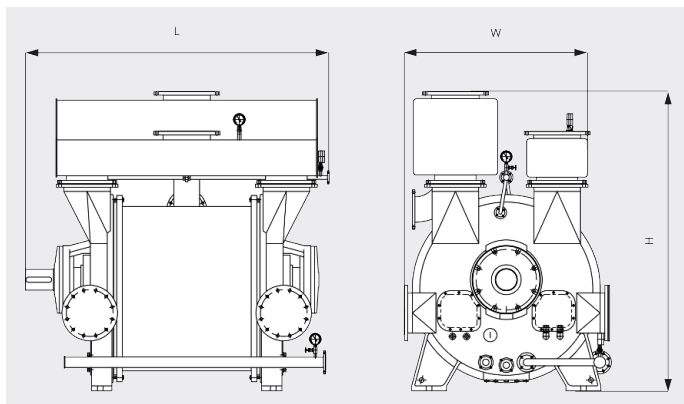

Pumping speed

Air at 20°C. Tolerance: ± 10%

— 50 Hz ..... 60 Hz

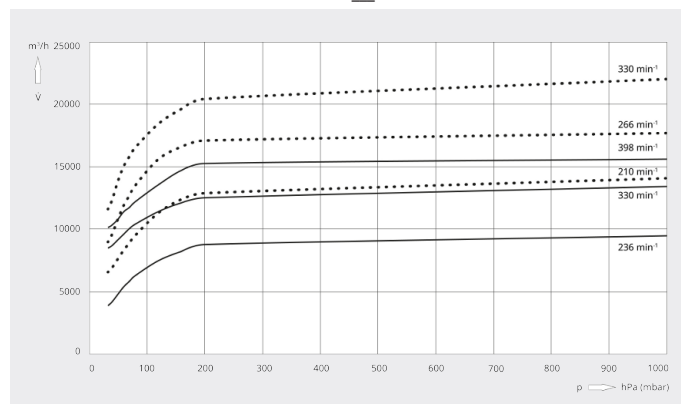

	DOLPHIN LR 1560 A	DOLPHIN LR 2200 A
Nominal pumping speed	9180.6 ACFM	12947.0 ACFM
Ultimate pressure	25 TORR	25 TORR
Nominal motor rating	600.0 HP	800.0 HP
Nominal motor speed	236 – 398 RPM	210–330 RPM
Noise level (ISO 2151)	< 85 dB(A)	< 85 dB(A)
Weight approx.	18348 Lbs.	26400 Lbs.
Dimensions (L x W x H)	98.9 x 70.3 x 100.8 inches	113.8 x 81.3 x 116.7 inches
Gas inlet / outlet	16" ANSI / 16" ANSI	20" ANSI / 20" ANSI

## DO YOU WANT TO KNOW MORE?

Get in touch with us directly!  
[info@buschusa.com](mailto:info@buschusa.com) or +1 757 463 7800



CONTACT FORM



CALL NOW