

# DOLPHIN LX 0260-0430 C

Liquid ring vacuum pumps



VACUUM SOLUTIONS



## Robust

Proven technology, reliable operation, extremely high particle and vapor tolerance, corrosion-free stainless steel impeller

## Compact

Directly flanged motor, no base frame required

## Flexible

Choice of cast iron (EN-GJL-200) or 316 grade stainless steel material housings, ATEX-certified version available (Cat. 2 (i) IIB, T4), operating fluids other than water possible

# DOLPHIN LX 0260-0430 C

Liquid ring vacuum pumps



VACUUM SOLUTIONS

Dimensional drawing

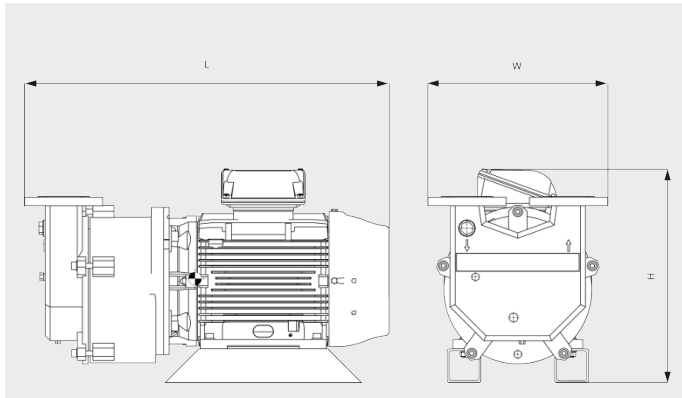

Pumping speed

Dry air at 70 °F. Operating fluid water 60°F. Tolerance: - 10%, in accordance with HEI and Pneurop 6612

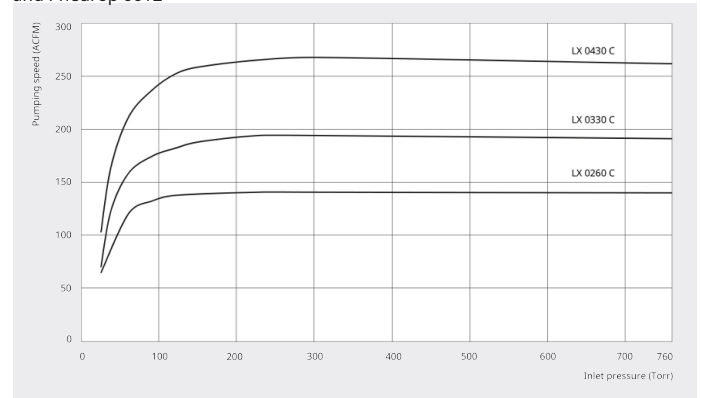

	DOLPHIN LX 0260 C	DOLPHIN LX 0330 C	DOLPHIN LX 0430 C
Nominal pumping speed	140.7 ACFM	194.2 ACFM	267.8 ACFM
Ultimate pressure	25 TORR	25 TORR	25 TORR
Nominal motor rating	10.0 HP	15.0 HP	20.0 HP
Nominal motor speed	1750 RPM	1750 RPM	1750 RPM
Noise level (ISO 2151)	72 dB(A)	72 dB(A)	72 dB(A)
Weight approx.	319.7 Lbs.	436.5 Lbs.	544.5 Lbs.
Dimensions (L x W x H)	26.5 x 14.4 x 15.8 inches	27.8 x 14.4 x 15.8 inches	33.9 x 16.7 x 19.9 inches
Gas inlet / outlet	2" ANSI / 2" ANSI	2" ANSI / 2" ANSI	2½" ANSI / 2½" ANSI

## DO YOU WANT TO KNOW MORE?

Get in touch with us directly!  
[info@buschusa.com](mailto:info@buschusa.com) or +1 757 463 7800



CONTACT FORM



CALL NOW