

DOLPHIN VL 0130-0320 A Continuous Flow

Liquid ring vacuum pump units

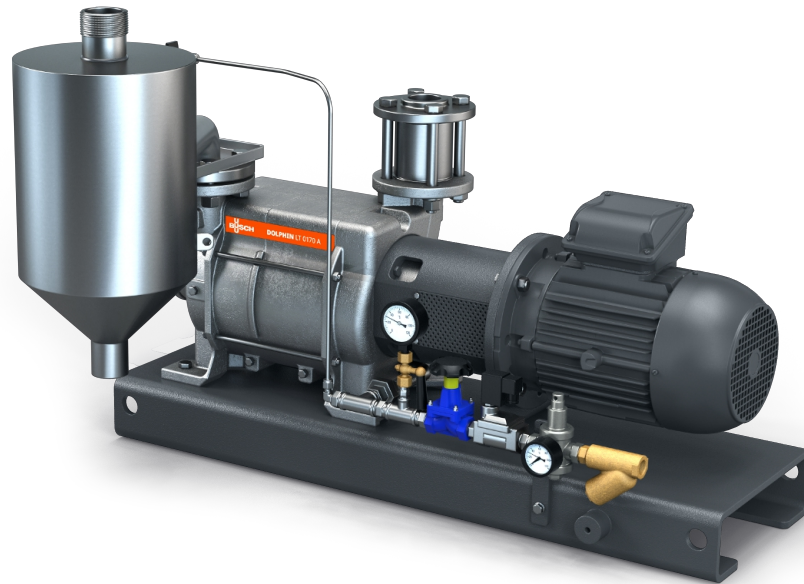

VACUUM SOLUTIONS



Robust

Proven technology, reliable operation, corrosion-free stainless steel impeller, extremely high vapor and particle tolerance, automatic solenoid valve for control of operating fluid flow from main supply

All-in-One

Unit with base frame, operating fluid separator, control system, including inlet check valve, fresh liquid supply kit, level indicator (ATEX only), temperature sensor (ATEX only) and pressure indicators and cavitation protection

Flexible

Choice of cast iron (EN-GJL-200) or 316 grade stainless steel material housings, ATEX-certified version available (Cat. 1 (i/o) IIC, T4), operating fluids other than water possible

DOLPHIN VL 0130-0320 A Continuous Flow

Liquid ring vacuum pump units



VACUUM SOLUTIONS

Dimensional drawing

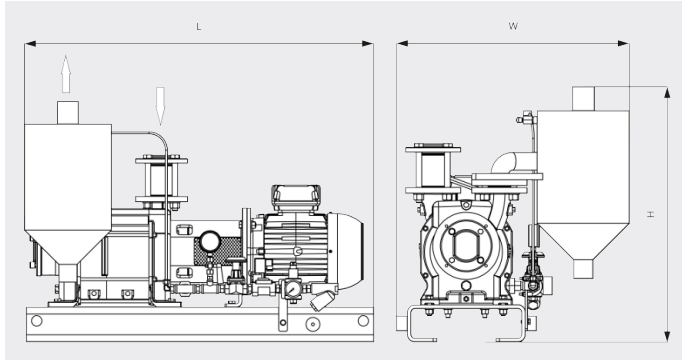

Dimensional drawing

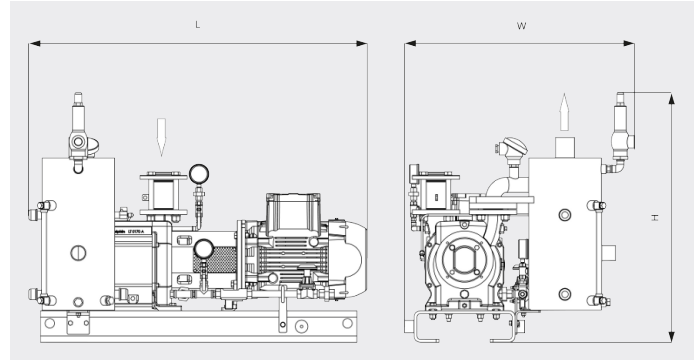

	DOLPHIN VL 0130 A Continuous Flow	DOLPHIN VL 0170 A Continuous Flow	DOLPHIN VL 0220 A Continuous Flow	DOLPHIN VL 0320 A Continuous Flow
Nominal pumping speed	75.3 ACFM	97.1 ACFM	136.5 ACFM	188.3 ACFM
Ultimate pressure	25 TORR	25 TORR	25 TORR	25 TORR
Nominal motor rating	5.4 HP	7.4 HP	10.1 HP	14.8 HP
Weight approx.	464.2 / 499.4 Lbs. (Safe / ATEX)	486.2 / 539 Lbs. (Safe / ATEX)	572 / 644.6 Lbs. (Safe / ATEX)	796.4 / 897.6 Lbs. (Safe / ATEX)
Dimensions (L x W x H)	39.6 x 24.9 x 27.2 / 40.8 x 28.6 x 31 inches (Safe / ATEX)	39.6 x 24.9 x 27.2 / 42.1 x 28.6 x 31 inches (Safe / ATEX)	43.4 x 24.9 x 27.2 / 47.5 x 28.6 x 31 inches (Safe / ATEX)	54.4 x 32.1 x 33.2 / 56.1 x 36.7 x 41.9 inches (Safe / ATEX)
Gas inlet / outlet	G 1½" / R 2"	G 1½" / R 2"	G 1½" / R 2"	G 2" / R 3"

DO YOU WANT TO KNOW MORE?

Get in touch with us directly!
info@buschusa.com or +1 757 463 7800



CONTACT FORM



CALL NOW