

# DOLPHIN VL 0130-0320 A Total Recirculation

Liquid ring vacuum pump units

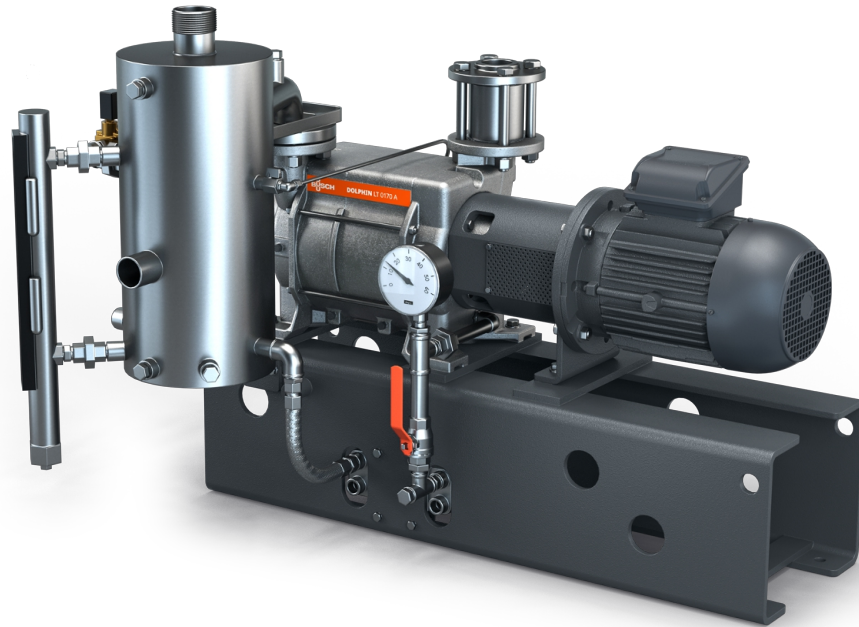

VACUUM SOLUTIONS



## Robust

Proven technology, reliable operation, corrosion-free stainless steel impeller, extremely high vapor and particle tolerance, choice of cast iron (EN-GJL-200) or 316 grade stainless steel material housings, ATEX-certified version available (Cat. 1 (i/o) IIC, T4)

## All-in-One

Unit with base frame, operating fluid separator, heat exchanger, control system, including inlet check valve, fresh liquid supply kit, level indicator with switches, temperature and pressure indicators and cavitation protection

## Efficient

Full recirculation of operating fluid, low operating fluid consumption, recovery of condensed vapors and process gases, isolation of cooling liquid from operating fluid, operating fluids other than water possible

# DOLPHIN VL 0130-0320 A Total Recirculation

Liquid ring vacuum pump units



VACUUM SOLUTIONS

Dimensional drawing

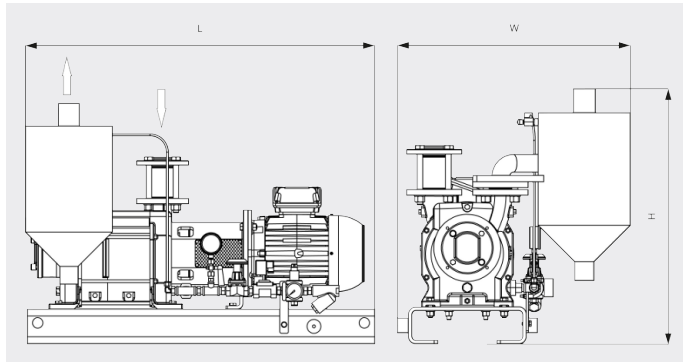

Dimensional drawing

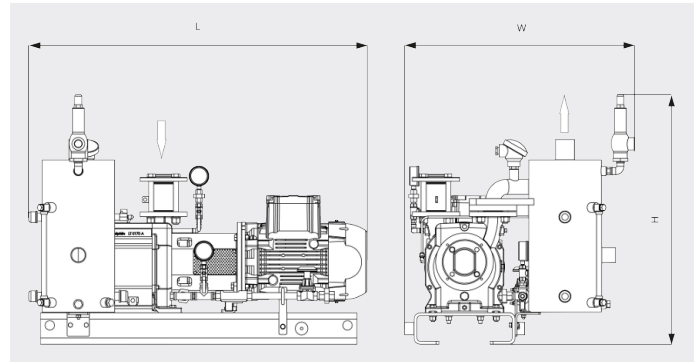

	DOLPHIN VL 0130 A Total Recirculation	DOLPHIN VL 0170 A Total Recirculation	DOLPHIN VL 0220 A Total Recirculation	DOLPHIN VL 0320 A Total Recirculation
<b>Nominal pumping speed</b>	75.3 ACFM	97.1 ACFM	136.5 ACFM	188.3 ACFM
<b>Ultimate pressure</b>	25 TORR	25 TORR	25 TORR	25 TORR
<b>Nominal motor rating</b>	5.4 HP	7.4 HP	10.1 HP	14.8 HP
<b>Weight approx.</b>	521.4 / 572 Lbs. (Safe / ATEX)	543.4 / 609.4 Lbs. (Safe / ATEX)	642.4 / 728.2 Lbs. (Safe / ATEX)	899.8 / 972.4 Lbs. (Safe / ATEX)
<b>Dimensions (L x W x H)</b>	57.5 x 28.6 x 32.2 / 57.4 x 29 x 37.6 inches (Safe / ATEX)	57.5 x 28.5 x 32.2 / 58.7 x 29 x 37.6 inches (Safe / ATEX)	61.4 x 28.6 x 32.2 / 64.1 x 29 x 37.6 inches (Safe / ATEX)	67.6 x 35.1 x 44.4 / 68.4 x 37.1 x 49.1 inches (Safe / ATEX)
<b>Gas inlet / outlet</b>	G 1½" / R 2"	G 1½" / R 2"	G 1½" / R 2"	G 2" / R 3"

## DO YOU WANT TO KNOW MORE?

Get in touch with us directly!  
[info@buschusa.com](mailto:info@buschusa.com) or +1 757 463 7800



CONTACT FORM



CALL NOW