

# APOVAC AP 0110–0180 A

Vacuum systems for chemical and pharmaceutical industries



## Proven performance

Standard vacuum system with proven DOLPHIN liquid ring vacuum pumps, specially designed for major processes in chemical and pharmaceutical industries, such as distillation, crystallization, filtration, vacuum drying

## Robust

Handling of toxic, corrosive or explosive gases, extremely high vapor and particle tolerance, for harsh process conditions, double condensation to ensure minimum carryover and maximum solvent recovery

## Cost-effective

Low operating costs, high uptime, minimal maintenance, long service life

# APOVAC AP 0110–0180 A

Vacuum systems for chemical and pharmaceutical industries



VACUUM SOLUTIONS

## Dimensional drawing

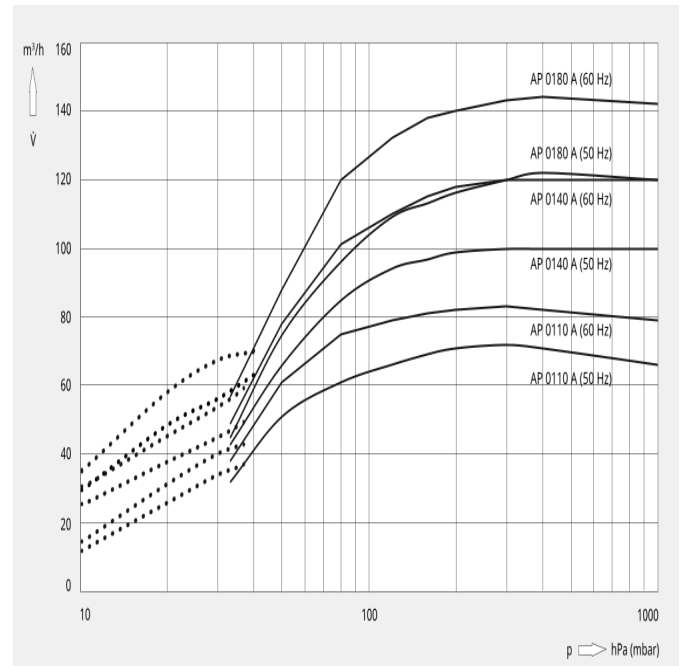
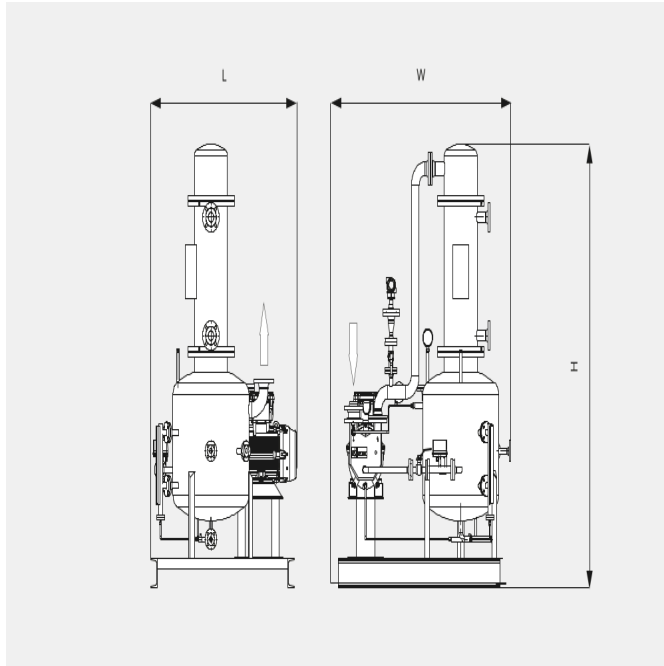

The following technical values refer to ISO 50 Hz

	AP 0110 A	AP 0140 A	AP 0180 A
<b>Nominal pumping speed</b>	72 m³/h	100 m³/h	122 m³/h
<b>Ultimate pressure</b>	33 hPa (mbar)	33 hPa (mbar)	33 hPa (mbar)
<b>Nominal motor rating</b>	2.2 kW	3.0 kW	4.0 kW
<b>Nominal motor speed</b>	1450 min <sup>-1</sup>	1450 min <sup>-1</sup>	1450 min <sup>-1</sup>
<b>Weight approx.</b>	600 kg	610 kg	620 kg
<b>Dimensions (L x W x H)</b>	1300 x 1300 x 1900 mm	1300 x 1300 x 1900 mm	1300 x 1300 x 1900 mm
<b>Gas inlet</b>	DN 40	DN 40	DN 40
<b>Gas outlet</b>	DN 50	DN 50	DN 50

The following technical values refer to ISO 60 Hz

	AP 0110 A	AP 0140 A	AP 0180 A
<b>Nominal pumping speed</b>	83 m³/h	120 m³/h	144 m³/h

# APOVAC AP 0110–0180 A

Vacuum systems for chemical and pharmaceutical industries



	AP 0110 A	AP 0140 A	AP 0180 A
<b>Ultimate pressure</b>	10 (with optional ejector) hPa (mbar)	10 (with optional ejector) hPa (mbar)	10 (with optional ejector) hPa (mbar)
<b>Nominal motor rating</b>	3.0 kW	4.0 kW	5.5 kW
<b>Nominal motor speed</b>	1750 min <sup>-1</sup>	1750 min <sup>-1</sup>	1750 min <sup>-1</sup>
<b>Weight approx.</b>	600 kg	610 kg	620 kg
<b>Dimensions (L x W x H)</b>	1300 x 1300 x 1900 mm	1300 x 1300 x 1900 mm	1300 x 1300 x 1900 mm
<b>Gas inlet</b>	DN 40	DN 40	DN 40
<b>Gas outlet</b>	DN 50	DN 50	DN 50

**DO YOU WANT TO KNOW MORE**

Please contact us!  
contact-uk@busch.co.uk or +44 (0) 1952 98 93 15



CONTACT FORM



CALL US NOW