

# R5 KB 0020-0040 D/F

Oil-lubricated rotary vane vacuum pumps



## Compact

Direct-drive construction, reduced height and weight, ideal for installation in vacuum packaging machines

## Reliable

Robust construction, highly durable vanes, proven rotary vane technology, long service life

## Flexible

Various design options available, easy adaption to individual customer requirements and processes

### Accessories

- Gas-ballast valve
- Filter pressure gauge
- Vacuum pump oils for all applications
- Various inlet filters
- Oil level switch
- Vacuum regulating unit

# R5 KB 0020-0040 D/F

Oil-lubricated rotary vane vacuum pumps



VACUUM SOLUTIONS

Dimensional drawing

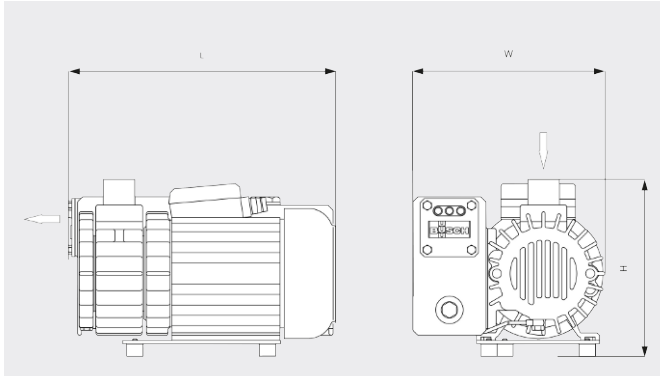

Pumping speed

Air at 20°C. Tolerance: ± 10%

— 50 Hz ..... 60 Hz

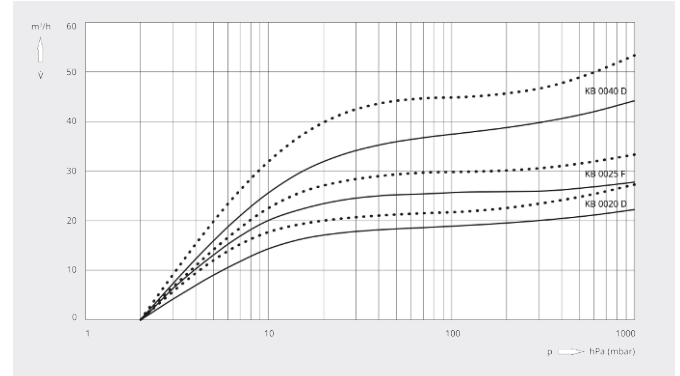

	R5 KB 0020 D	R5 KB 0025 F	R5 KB 0040 D
<b>Nominal pumping speed</b>	20 / 24 m <sup>3</sup> /h (50 / 60 Hz)	25 / 30 m <sup>3</sup> /h (50 / 60 Hz)	40 / 48 m <sup>3</sup> /h (50 / 60 Hz)
<b>Ultimate pressure</b>	2.0 hPa (mbar) (50 / 60 Hz)	2.0 hPa (mbar) (50 / 60 Hz)	2.0 hPa (mbar) (50 / 60 Hz)
<b>Nominal motor rating</b>	0.75 kW (50 / 60 Hz)	0.9 / 1.1 kW (50 / 60 Hz)	1.5 kW (50 / 60 Hz)
<b>Nominal motor speed</b>	3000 / 3600 min <sup>-1</sup> (50 / 60 Hz)	3000 / 3600 m <sup>3</sup> /h (50 / 60 Hz)	3000 / 3600 min <sup>-1</sup> (50 / 60 Hz)
<b>Noise level (ISO 2151)</b>	67 / 70 dB(A) (50 / 60 Hz)	71 / 73 dB(A) (50 / 60 Hz)	71 / 75 dB(A) (50 / 60 Hz)
<b>Oil capacity</b>	0.45 l	0.45 l	0.8 l
<b>Weight approx.</b>	19 kg	20 kg	29 kg
<b>Dimensions (L x W x H)</b>	323 x 231 x 211 mm	347 x 250 x 229 mm	432 x 256 x 238 mm
<b>Gas inlet / outlet</b>	G ¾" / -	G ¾" / -	G 1¼" G 1¼"

## DO YOU WANT TO KNOW MORE?

Get in touch with us directly!  
[sales@busch.co.uk](mailto:sales@busch.co.uk) or +44 (0)1952 67 74 32



CONTACT FORM



CALL NOW