

MINK MM 1104/1102 CVM

Dry claw vacuum pumps



VACUUM SOLUTIONS



Reliable

More than 50,000 MINK vacuum pumps in operation in milking robots and plants, proven dry claw vacuum technology, no operating fluids, nearly maintenance-free, long service life

Efficient

Up to 25% energy savings compared to conventional vacuum generators used for milking robots and plants

Flexible

Wide frequency range from 10 to 60 Hz

MINK MM 1104/1102 CVM

Dry claw vacuum pumps



VACUUM SOLUTIONS

Dimensional drawing

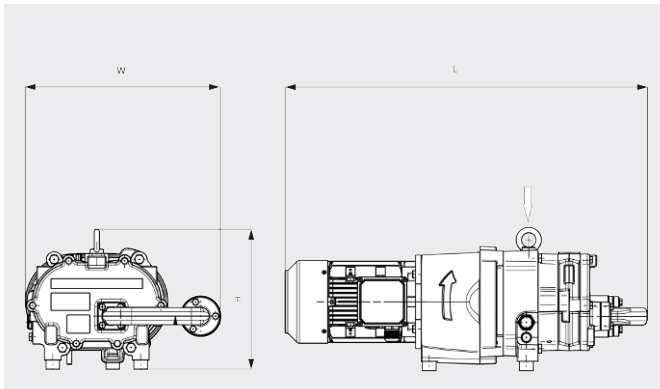

Pumping speed

Air at 20°C. Tolerance: ± 10%

— 50 Hz 60 Hz

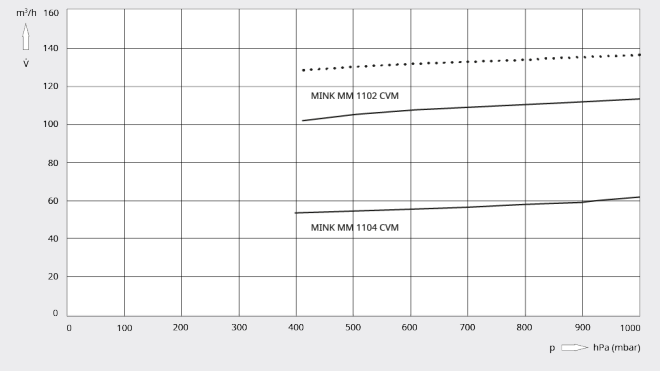

	MM 1104 CVM	MM 1102 CVM	MM 1102 CVM
Nominal pumping speed	62 m ³ /h (50 Hz)	110 m ³ /h (50 Hz)	110 / 135 m ³ /h (50 / 60 Hz)
Ultimate pressure	400 hPa (mbar) (50 Hz)	400 hPa (mbar) (50 Hz)	400 hPa (mbar) (50 / 60 Hz)
Nominal motor rating	1.3 kW (50 Hz)	2.2 kW (50 Hz)	3.0 / 3.4 kW (50 / 60 Hz)
Nominal motor speed	1500 min ⁻¹ (50 Hz)	3000 min ⁻¹ (50 Hz)	3000 / 3600 min ⁻¹ (50 / 60 Hz)
Noise level (ISO 2151)	72 dB(A) (50 Hz)	70 dB(A) (50 Hz)	73 / 77 dB(A) (50 / 60 Hz)
Oil capacity	0.5 l	0.5 l	0.5 l
Weight approx.	78 kg *	140 kg *	140 kg *
Dimensions (L x W x H)	771 x 428 x 306 mm	898 x 339 x 301 mm	898 x 339 x 301 mm

DO YOU WANT TO KNOW MORE?

Get in touch with us directly!
sales@busch.co.uk or +44 (0)1952 67 74 32



CONTACT FORM



CALL NOW