

R5 RA 0520 A ECOTORQUE

Oil-lubricated rotary vane vacuum pump



VACUUM SOLUTIONS



Efficient

Up to 50% energy savings thanks to the variable speed drive (VSD), automatic start and stop function with Ecomode

High performance

High pumping speed at low pressure ranges, designed for continuous operation in the rough vacuum range, best-in-class footprint performance ratio

Flexible

Precise adjustment of vacuum level (pressure control) and pumping speed (speed control) to process requirements, compatible with a wide range of supply voltages

R5 RA 0520 A ECOTORQUE

Oil-lubricated rotary vane vacuum pump



VACUUM SOLUTIONS

Dimensional drawing

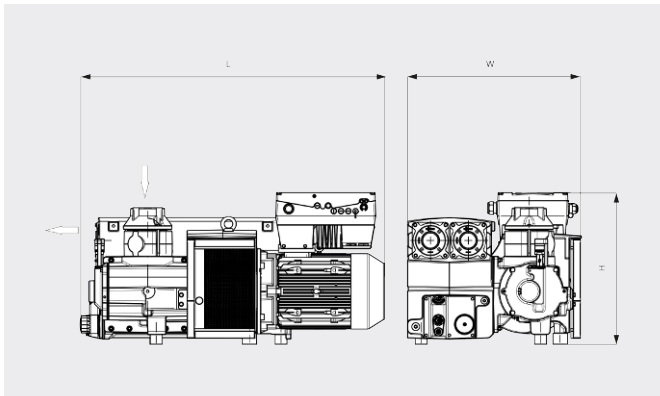

Pumping speed

Air at 20°C. Tolerance: ± 10%

— Min. speed Max. speed

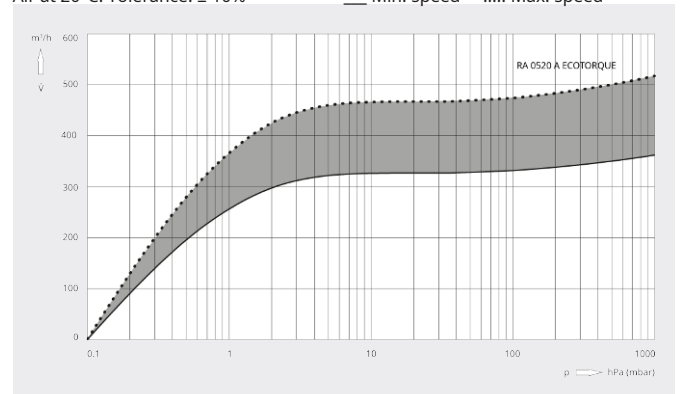

| R5 RA 0520 A ECOTORQUE | |
|--|------------------------------|
| Nominal pumping speed | 330 – 520 m ³ /h |
| Ultimate pressure | 0.1 hPa (mbar) |
| Nominal motor speed | 800 – 1200 min ⁻¹ |
| Power consumption at ultimate pressure | 2.6 – 3.9 kW |
| Noise level (ISO 2151) | 67 – 76 dB(A) |
| Oil capacity | 11 l |
| Weight approx. | 441 kg |
| Dimensions (L x W x H) | 1253 x 718 x 626 mm |
| Gas inlet * | G 3" |

*Gas outlet G 3" optional

DO YOU WANT TO KNOW MORE?

Get in touch with us directly!
sales@busch.co.uk or +44 (0)1952 67 74 32



CONTACT FORM



CALL NOW