

# DOLPHIN LR 0420/0580 A

Liquid ring vacuum pumps



VACUUM SOLUTIONS



## Robust

Proven technology, reliable operation, extremely high vapor and particle tolerance, specially designed for challenging environments like mining, power plants, sugar production, pulp and paper industry, steel production etc.

## High performance

High-capacity, high pumping speeds

## Flexible

Modular design, choice of cast iron (EN-GJL-200) housing with ductile cast iron impeller or all 304 grade, or 316L grade corrosion-free stainless steel material, operating fluids other than water possible, operation as compressor possible

Accessories, spare parts and options

- Motorized pumpsets, with gearbox or V-belt drive system
- Sturdy, steel mounting baseframes
- Partial or total recirculation systems
- Cavitation protection
- Gas ejector
- Non-return valves
- Vacuum relief valves
- Temporary inlet screens (for commissioning)

# DOLPHIN LR 0420/0580 A

Liquid ring vacuum pumps



VACUUM SOLUTIONS

Dimensional drawing

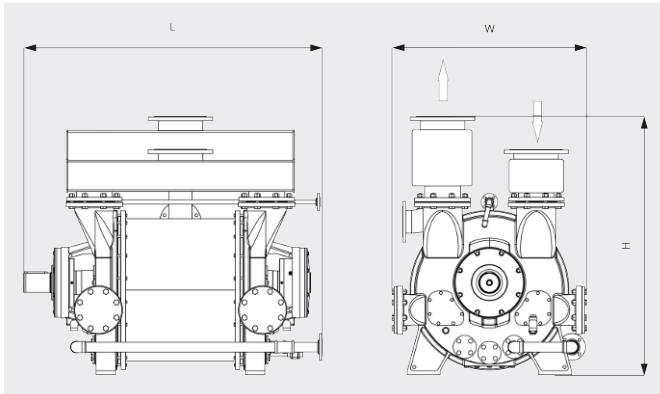

Pumping speed

Dry air at 20°C. Tolerance: ± 10%, in accordance with HEI and Pneurop 6612

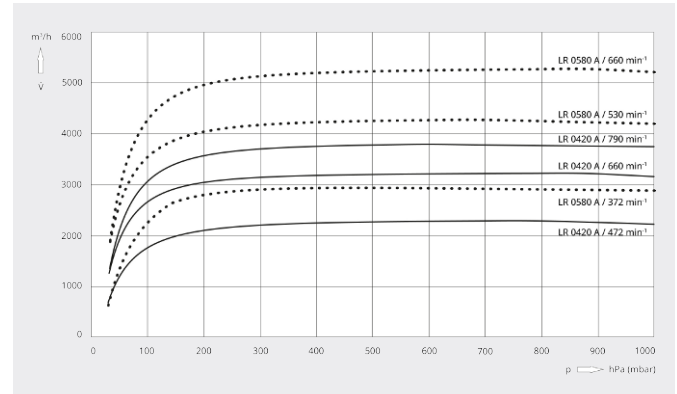

	DOLPHIN LR 0420 A	DOLPHIN LR 0580 A
Nominal pumping speed	2250 – 3830 m <sup>3</sup> /h	2900 – 5300 m <sup>3</sup> /h
Ultimate pressure	33 hPa (mbar)	33 hPa (mbar)
Nominal motor rating	55 – 132 kW	75 – 185 kW
Rotational speed of vacuum pump	472 – 790 min <sup>-1</sup>	372 – 660 min <sup>-1</sup>
Noise level (ISO 2151)	≤ 85 dB(A)	≤ 85 dB(A)
Weight approx.	1572 kg	2233 kg
Dimensions (L x W x H)	1670 x 1030 x 1360 mm	1819 x 1160 x 1570 mm
Gas inlet / outlet	DN 200 PN 10 / DN 200 PN 10	DN 250 PN 10 / DN 250 PN 10

DO YOU WANT TO KNOW MORE?

Get in touch with us directly!  
[sales@busch.co.uk](mailto:sales@busch.co.uk) or +44 (0)1952 67 74 32



CONTACT FORM



CALL NOW