

# DOLPHIN LG 0890/1200 A

Liquid ring vacuum pumps



VACUUM SOLUTIONS



## Robust

Proven technology, reliable operation, extremely high vapor and particle tolerance, specially designed for challenging environments like mining, power plants, sugar production, pulp and paper industry, steel production etc.

## High performance

High-capacity, high pumping speeds

## Flexible

Modular design, choice of cast iron (EN-GJL-200) housing with ductile cast iron impeller or all 316 grade corrosion-free stainless steel material, operating fluids other than water possible, operation as compressor possible

### Accessories

- Motorized pumpsets, with gearbox or V-belt drive system, mounted on sturdy steel base frames
- Partial or total recirculation systems
- Cavitation protection
- Gas ejector
- Non-return valves
- Vacuum relief valves

# DOLPHIN LG 0890/1200 A

Liquid ring vacuum pumps



VACUUM SOLUTIONS

Dimensional drawing

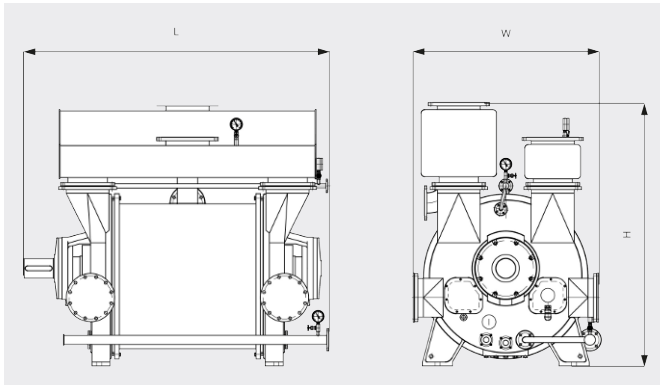

Pumping speed

Air at 20°C. Tolerance: ± 10%

— 50 Hz ..... 60 Hz

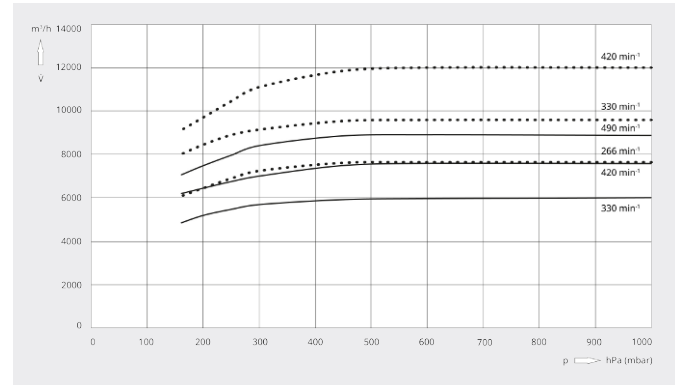

	DOLPHIN LG 0890 A	DOLPHIN LG 1200 A
Nominal pumping speed	6000 – 8900 m <sup>3</sup> /h	7650 – 12000 m <sup>3</sup> /h
Ultimate pressure	160 hPa (mbar)	160 hPa (mbar)
Nominal motor rating	132 – 220 kW	160 – 280 kW
Nominal motor speed	330 – 490 min <sup>-1</sup>	266 – 420 min <sup>-1</sup>
Noise level (ISO 2151)	< 85 dB(A)	< 85 dB(A)
Weight approx.	3880 kg	5760 kg
Dimensions (L x W x H)	2370 x 1330 x 1865 mm	2500 x 1550 2160 mm
Gas inlet / outlet	DN 300 PN 10 / DN 300 PN 10	DN 350 PN 10 / DN 350 PN 10

## DO YOU WANT TO KNOW MORE?

Get in touch with us directly!  
[sales@busch.co.uk](mailto:sales@busch.co.uk) or +44 (0)1952 67 74 32



CONTACT FORM



CALL NOW