

R5 RA 1000/1600 B

Oil-lubricated rotary vane vacuum pumps



VACUUM SOLUTIONS



Reliable

Robust construction, highly resilient carbon fiber vanes, proven rotary vane technology, long service life

High performance

High pumping speed at low pressures, designed for continuous operation

Flexible

Various design options available, easy adaption to individual customer requirements and processes, level and temperature switch as standard

Accessories

- IEC (IE3) and NEMA motors
- Multi-voltage, multi-frequency motors (IE3) for variable speed drive
- Single or double gas-ballast valve, manual or solenoid operation
- Various inlet filters
- Inlet filter pressure gauge
- Various temperature and pressure gauges
- Starter units
- Oil mist separator
- Energy recuperation kit with heat exchanger
- Vacuum pump oils for all applications

R5 RA 1000/1600 B

Oil-lubricated rotary vane vacuum pumps



VACUUM SOLUTIONS

Dimensional drawing

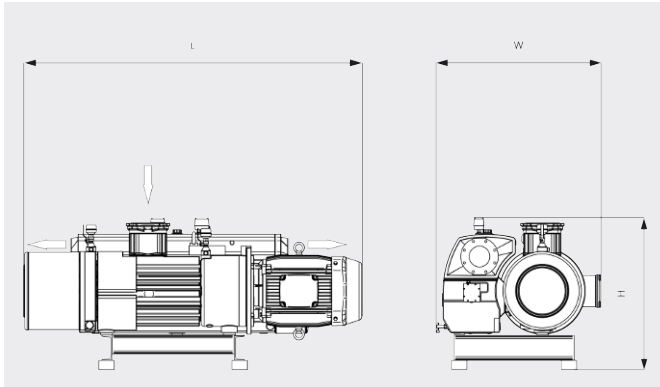

Pumping speed

Air at 20°C. Tolerance: ± 10%

— 50 Hz 60 Hz

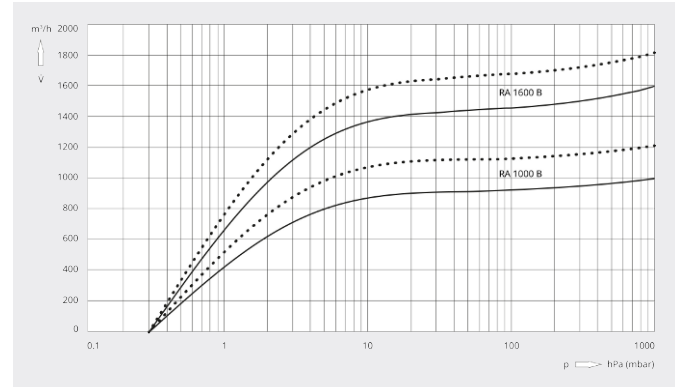

	R5 RA 1000 B	R5 RA 1600 B
Nominal pumping speed	1000 / 1200 m ³ /h (50 / 60 Hz)	1600 / 1800 m ³ /h (50 / 60 Hz)
Ultimate pressure	0.3 hPa (mbar) (50 / 60 Hz)	0.3 hPa (mbar) (50 / 60 Hz)
Nominal motor rating	22.0 / 30.0 kW (50 / 60 Hz)	30.0 / 37.0 kW (50 / 60 Hz)
Nominal motor speed	1000 / 1200 min ⁻¹ (50 / 60 Hz)	1000 / 1200 min ⁻¹ (50 / 60 Hz)
Power consumption at 100 mbar	17.3 / 22.4 kW (50 / 60 Hz)	26.8 / 33.0 kW (50 / 60 Hz)
Power consumption at ultimate pressure	9.3 / 12.1 kW (50 / 60 Hz)	13.8 / 17.9 kW (50 / 60 Hz)
Noise level (ISO 2151)	82 dB(A) (50 / 60 Hz)	83 dB(A) (50 / 60 Hz)
Oil capacity	30 l	30 l
Weight approx.	1000 / 1060 kg	1330 / 1350 kg
Dimensions (L x W x H)	1894 x 1003 x 936 mm	2234 x 1040 x 936 mm
Gas inlet / outlet	DN 150 / DN 125	DN 150 / DN 125

DO YOU WANT TO KNOW MORE?

Get in touch with us directly!
vakutek@ttmail.com or +90 (0)2163100573



CONTACT FORM



CALL NOW