

# PANDA WV 4500 B

Vacuum boosters



VACUUM SOLUTIONS



## Reliable

Solid lobe design, robust construction, reliable under varying operating conditions, barrier gas connection

## High performance

Excellent volumetric efficiency, high ultimate pressure, increases the performance of a vacuum system by up to a factor of ten, integrated bypass valve, specially designed for rough and medium vacuum applications

## Flexible

Can be flanged directly on the system at any position, boosts the performance of all types of backing pumps, with vertical or lateral discharge, perfectly suited for a wide range of applications

# PANDA WV 4500 B

Vacuum boosters



VACUUM SOLUTIONS

Dimensional drawing

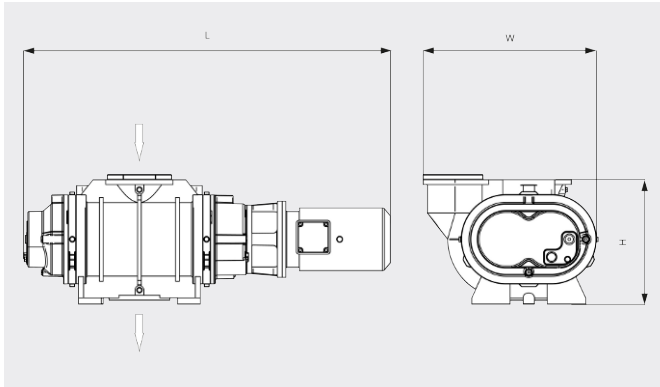

Pumping speed

Air at 20°C. Tolerance: ± 10%

— 50 Hz ..... 60 Hz

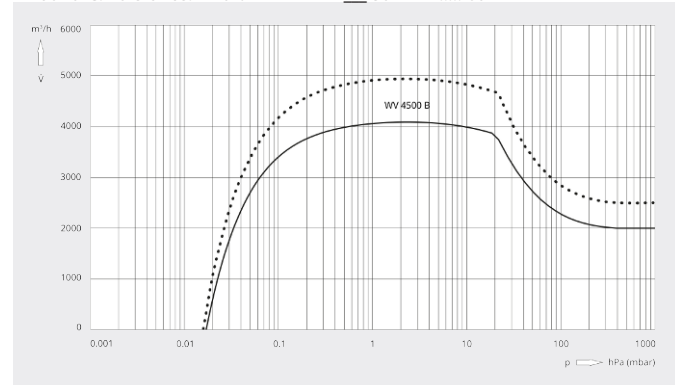

PANDA WV 4500 B	
Nominal pumping speed	4500 / 5400 m³/h (50 / 60 Hz)
Pumping speed	4100 / 4950 m³/h (50 / 60 Hz)
Max. differential pressure	25 hPa (mbar) (50 / 60 Hz)
Nominal motor rating	11.0 / 12.6 kW (50 / 60 Hz)
Nominal motor speed	3000 / 3600 min <sup>-1</sup> (50 / 60 Hz)
Weight approx.	690 kg
Dimensions (L x W x H)	690 x 690 x 510 mm
Gas inlet / outlet	DN 250 ISO / DN 160 ISO

## DO YOU WANT TO KNOW MORE?

Get in touch with us directly!  
[info@busch.com.tr](mailto:info@busch.com.tr) or +90 216 912 46 04



CONTACT FORM



CALL NOW