

COBRA NC 0100-0300 B

Dry screw vacuum pumps



VACUUM SOLUTIONS



High performance

Advanced screw design, patented self-balancing screws, perfectly suited for chemical processes, distillation and vacuum drying

Efficient

Low cost of ownership, minimal maintenance, long service intervals, high uptime, efficient water cooling

Flexible

Air cooling, various sealing and coating configurations as well as ATEX-certified versions available

Accessories

- Purge gas system
- Sealing gas supply
- Dilution gas supply
- Connection adapter to connect ISO or ASME flanges
- Non-return valve
- Exhaust gas silencer
- Air cooling
- Various sealing and coating configurations
- ATEX-certified versions available

COBRA NC 0100-0300 B

Dry screw vacuum pumps



Dimensional drawing

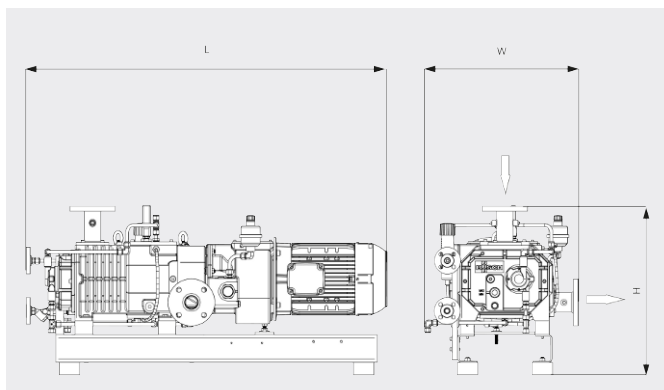

Pumping speed

Air at 20°C. Tolerance: ± 10%

— 50 Hz 60 Hz

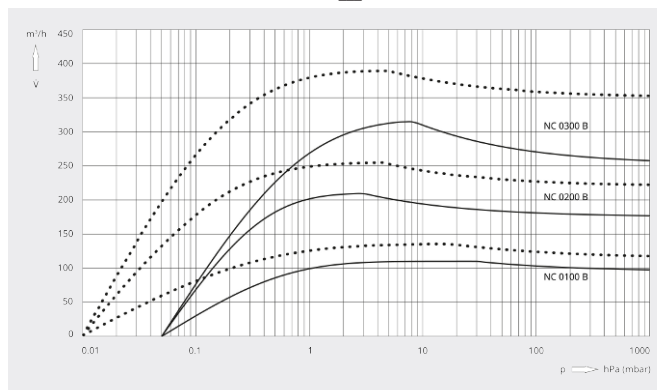

	COBRA NC 0100 B	COBRA NC 0200 B	COBRA NC 0300 B
Pumping speed	110 / 130 m³/h (50 / 60 Hz)	220 / 265 m³/h (50 / 60 Hz)	320 / 385 m³/h (50 / 60 Hz)
Ultimate pressure	≤ 0.05 / ≤ 0.01 hPa (mbar) (50 / 60 Hz)	≤ 0.05 / ≤ 0.01 hPa (mbar) (50 / 60 Hz)	≤ 0.05 / ≤ 0.01 hPa (mbar) (50 / 60 Hz)
Nominal motor rating	3.5 / 4.8 kW (50 / 60 Hz)	6.0 / 7.6 kW (50 / 60 Hz)	7.5 / 9.5 kW (50 / 60 Hz)
Nominal motor speed	3000 / 3600 min ⁻¹ (50 / 60 Hz)	3000 / 3600 min ⁻¹ (50 / 60 Hz)	3000 / 3600 min ⁻¹ (50 / 60 Hz)
Noise level (ISO 2151)	≤ 70 / ≤ 74 dB(A) (50 / 60 Hz)	≤ 71 / ≤ 76 dB(A) (50 / 60 Hz)	≤ 72 / ≤ 77 dB(A) (50 / 60 Hz)
Weight approx.	300 kg	350 kg	400 kg
Dimensions (L x W x H)	1127 x 520 x 595 mm	1264 x 520x 607 mm	1334 x 520 x 607 mm
Gas inlet / outlet	DN 40 PN 16 / DN 40 PN 16	DN 50 PN 16 / DN 50 PN 16	DN 50 PN 16 / DN 50 PN 16

DO YOU WANT TO KNOW MORE?

Get in touch with us directly!
vakutek@ttmail.com or +90 (0)2163100573



CONTACT FORM



CALL NOW