

DOLPHIN LR 0110/0140 A

Liquid ring vacuum pumps



VACUUM SOLUTIONS



Robust

Proven technology, reliable operation, extremely high vapor and particle tolerance, specially designed for challenging environments like mining, power plants, sugar production, pulp and paper industry, steel production etc.

High performance

High-capacity, high pumping speeds

Flexible

Modular design, choice of cast iron (EN-GJL-200) housing with ductile cast iron impeller or all 304 grade, or 316L grade corrosion-free stainless steel material, operating fluids other than water possible, operation as compressor possible

Accessories, spare parts and options

- Motorized pumpsets, with gearbox or V-belt drive system
- Sturdy, steel mounting baseframes
- Partial or total recirculation systems
- Cavitation protection
- Gas ejector
- Non-return valves
- Vacuum relief valves
- Temporary inlet screens (for commissioning)

DOLPHIN LR 0110/0140 A

Liquid ring vacuum pumps



VACUUM SOLUTIONS

Dimensional drawing

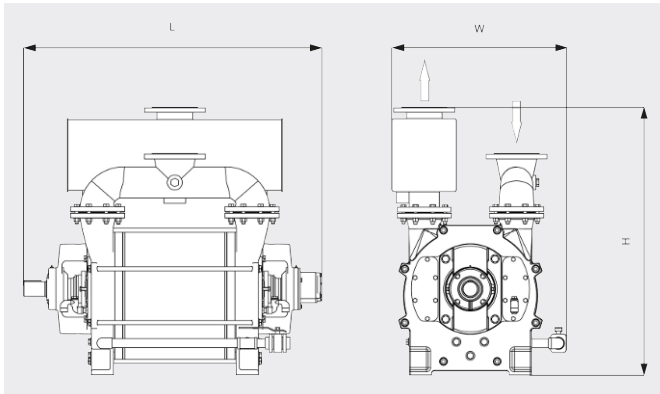

Pumping speed

Dry air at 20°C. Tolerance: ± 10%, in accordance with HEI and Pneurop 6612

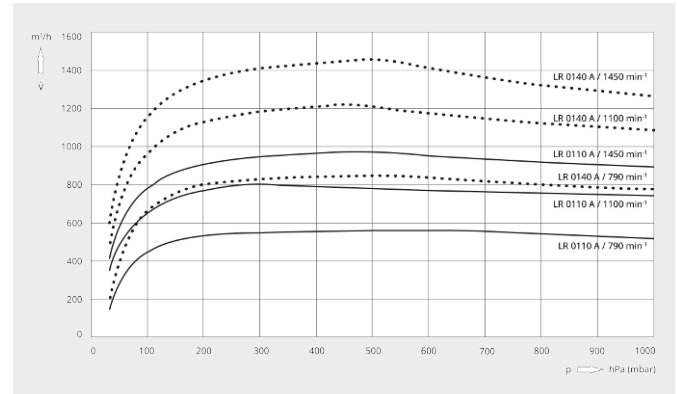

	DOLPHIN LR 0110 A	DOLPHIN LR 0140 A
Nominal pumping speed	570 – 960 m ³ /h	840 – 1430 m ³ /h
Ultimate pressure	33 hPa (mbar)	33 hPa (mbar)
Nominal motor rating	18.5 – 45 kW	30 – 55 kW
Rotational speed of vacuum pump	790 – 1450 min ⁻¹	790 – 1450 min ⁻¹
Noise level (ISO 2151)	≤ 80 dB(A)	≤ 80 dB(A)
Weight approx.	454 kg	511 kg
Dimensions (L x W x H)	975 x 700 x 985 mm	1095 x 700 x 985 mm
Gas inlet / outlet	DN 125 PN 10 / DN 125 PN 10	DN 125 PN 10 / DN 125 PN 10

DO YOU WANT TO KNOW MORE?

Get in touch with us directly!
info@busch.co.th or +66 2 02 66 113



CONTACT FORM



CALL NOW