

PANDA WZ 0250-2000 B

Vacuum boosters

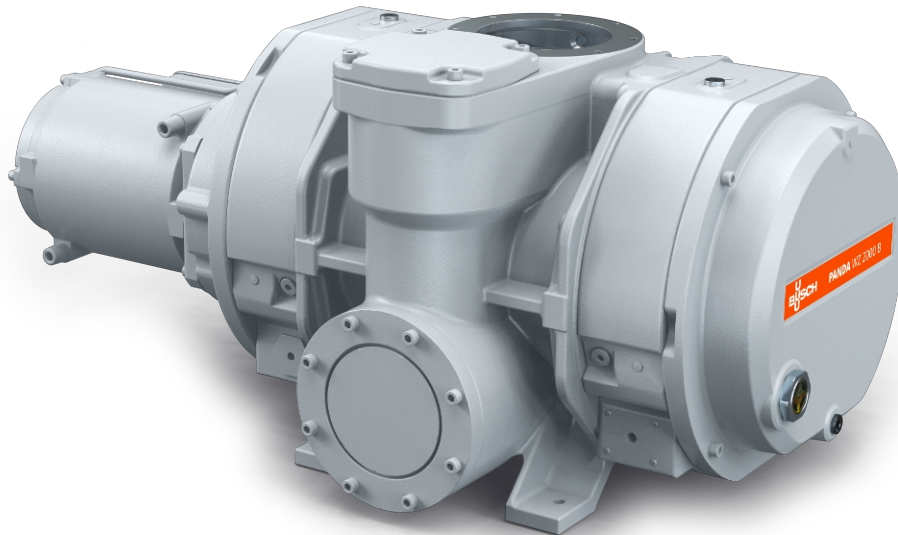

VACUUM SOLUTIONS



Reliable

Solid lobe design, robust construction, reliable under varying operating conditions, leak-tight, barrier gas connection

High performance

Excellent volumetric efficiency, high ultimate pressure, increases the performance of a vacuum system by up to a factor of ten, integrated bypass valve, specially designed for medium and high vacuum applications including semiconductor processes

Flexible

Can be flanged directly on the system at any position, boosts the performance of all types of backing pumps, with vertical or lateral discharge

PANDA WZ 0250-2000 B

Vacuum boosters



VACUUM SOLUTIONS

Dimensional drawing

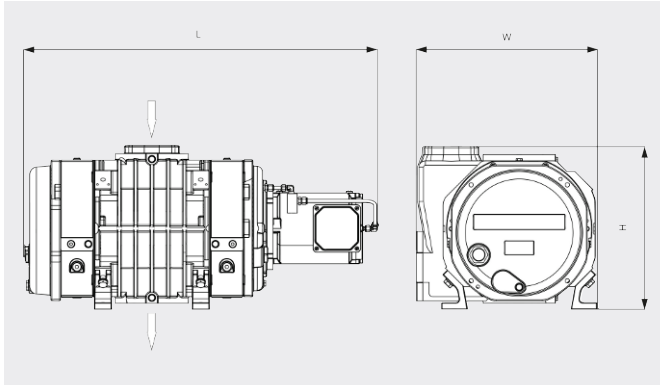

Pumping speed

Air at 20°C. Tolerance: ± 10%

— 50 Hz 60 Hz

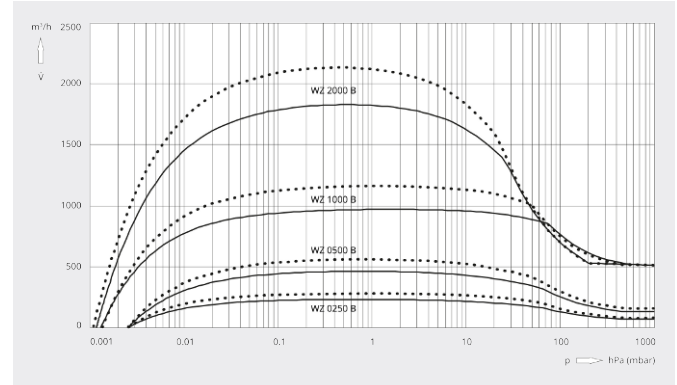

	PANDA WZ 0250 B	PANDA WZ 0500 B	PANDA WZ 1000 B	PANDA WZ 2000 B
Nominal pumping speed	263 / 315 m³/h (50 / 60 Hz)	525 / 630 m³/h (50 / 60 Hz)	1050 / 1260 m³/h (50 / 60 Hz)	2120 / 2540 m³/h (50 / 60 Hz)
Pumping speed	233 / 281 m³/h (50 / 60 Hz)	464 / 560 m³/h (50 / 60 Hz)	971 / 1160 m³/h (50 / 60 Hz)	1830 / 2132 m³/h (50 / 60 Hz)
Max. differential pressure	100 hPa (mbar) (50 / 60 Hz)	100 hPa (mbar) (50 / 60 Hz)	53 hPa (mbar) (50 / 60 Hz)	43 hPa (mbar) (50 / 60 Hz)
Leakage rate	≤ 1 · 10 ⁻⁶ mbar · l/s	≤ 1 · 10 ⁻⁶ mbar · l/s	≤ 1 · 10 ⁻⁶ mbar · l/s	≤ 1 · 10 ⁻⁶ mbar · l/s
Nominal motor rating	1.5 / 1.8 kW (50 / 60 Hz)	4.0 / 4.4 kW (50 / 60 Hz)	4.0 / 4.4 kW (50 / 60 Hz)	5.5 / 6.6 kW (50 / 60 Hz)
Nominal motor speed	1500 / 1800 min ⁻¹ (50 / 60 Hz)	3000 / 3600 min ⁻¹ (50 / 60 Hz)	3000 / 3600 min ⁻¹ (50 / 60 Hz)	3000 / 3600 min ⁻¹ (50 / 60 Hz)
Weight approx.	165 kg	175 kg	270 kg	510 kg
Dimensions (L x W x H)	819 x 372 x 422 mm	819 x 372 x 422 mm	870 x 402 x 483 mm	1086 x 558 x 503 mm
Gas inlet / outlet (vertical)	DN 100 ISO / DN 100 ISO	DN 100 ISO / DN 100 ISO	DN 160 ISO / DN 100 ISO	DN 160 ISO / DN 160 ISO
Gas inlet / outlet (horizontal)	DN 100 ISO / DN 63 ISO	DN 100 ISO / DN 63 ISO	DN 160 ISO / DN 100 ISO	DN 160 ISO / DN 160 ISO

DO YOU WANT TO KNOW MORE?

Get in touch with us directly!
info@busch.co.th or +66 2 02 66 113



CONTACT FORM



CALL NOW