

SECO SD 1010-1040 C/D

Dry-running rotary vane compressors



VACUUM SOLUTIONS



Compact

Direct-drive construction

Reliable

Robust construction, proven performance, self-lubricating vanes, no operating fluids

High performance

High performance Aerodur 274 Zirkon vanes, extended lifetime, extremely resistant to wear and humidity

Accessories, spare parts and options

- Inlet filter
- Non-return valve (exhaust)
- Hose nipple
- Pressure relief valve

SECO SD 1010-1040 C/D

Dry-running rotary vane compressors



VACUUM SOLUTIONS

Dimensional drawing

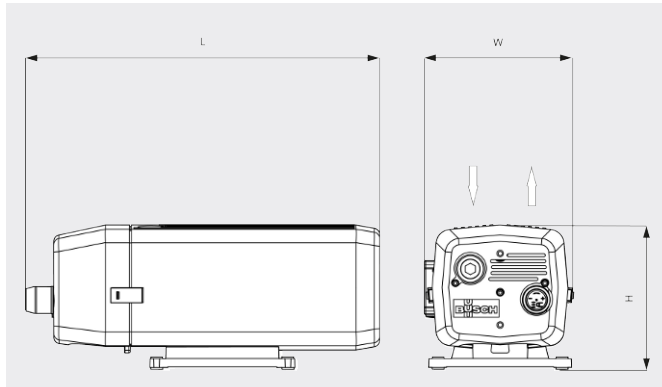

Volume flow

Air at 20°C. Tolerance: ± 10%

— 50 Hz 60 Hz

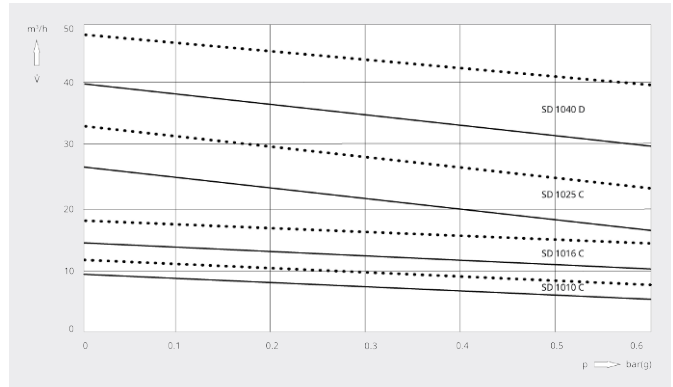

	SECO SD 1010 C	SECO SD 1016 C	SECO SD 1025 C	SECO SD 1040 D
Volume flow	9 / 12 m³/h (50 / 60 Hz)	15 / 18 m³/h (50 / 60 Hz)	26 / 33 m³/h (50 / 60 Hz)	40 / 48 m³/h (50 / 60 Hz)
Overpressure	0.6 bar(g) (50 / 60 Hz)	0.6 bar(g) (50 / 60 Hz)	0.6 bar(g) (50 / 60 Hz)	0.6 bar(g) (50 / 60 Hz)
Nominal motor rating	0.37 kW (50 / 60 Hz)	0.55 kW (50 / 60 Hz)	0.9 kW (50 / 60 Hz)	1.25 kW (50 / 60 Hz)
Nominal motor speed	1500 / 1800 min ⁻¹ (50 / 60 Hz)	1500 / 1800 min ⁻¹ (50 / 60 Hz)	1500 / 1800 min ⁻¹ (50 / 60 Hz)	1500 / 1800 min ⁻¹ (50 / 60 Hz)
Noise level (ISO 2151)	56 / 58 dB(A) (50 / 60 Hz)	57 / 60 dB(A) (50 / 60 Hz)	64 / 66 dB(A) (50 / 60 Hz)	67 / 70 dB(A) (50 / 60 Hz)
Weight approx.	21 kg	25 kg	33 kg	38 kg
Dimensions (L x W x H)	413 x 239 x 224 mm	440 x 239 x 224 mm	499 x 253 x 246 mm	554 x 257 x 246 mm
Gas inlet / outlet	G ½" / G ½"	G ½" / G ½"	G ¾" / G ¾"	G ¾" / G ¾"

DO YOU WANT TO KNOW MORE?

Get in touch with us directly!
sales@busch.com.sg or +65 (0)64 88 08 66



CONTACT FORM



CALL NOW