

DOLPHIN LB 0063-0184 A

Liquid ring vacuum pumps

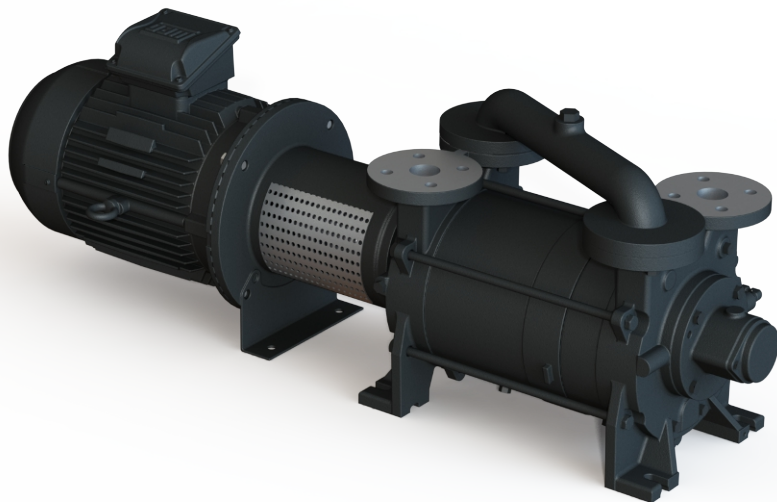

Robust

Proven technology, durable two-stage construction

Reliable

Extremely high vapor and particle tolerance

Flexible

Wide range of construction materials, including cast iron (EN-GJL-200), many grades of stainless steel and even titanium, ATEX-certified version available (Cat 1(i)/2(o) IIC T5), operating fluids other than water possible, operation as compressor possible

Accessories, spare parts and options

- Partial or total recirculation systems
- Liquid separator
- Cavitation protection
- Heat exchanger
- Gas ejector
- Wide selection of motors
- Non-return valves
- Vacuum relief valves

DOLPHIN LB 0063-0184 A

Liquid ring vacuum pumps



VACUUM SOLUTIONS

Dimensional drawing

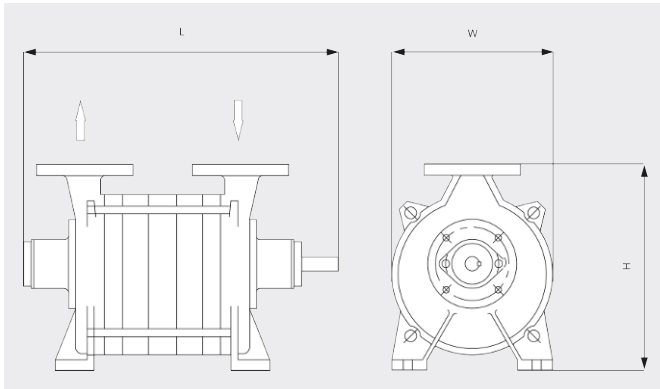

Pumping speed

Air at 20°C. Tolerance: ± 10%

— 50 Hz 60 Hz

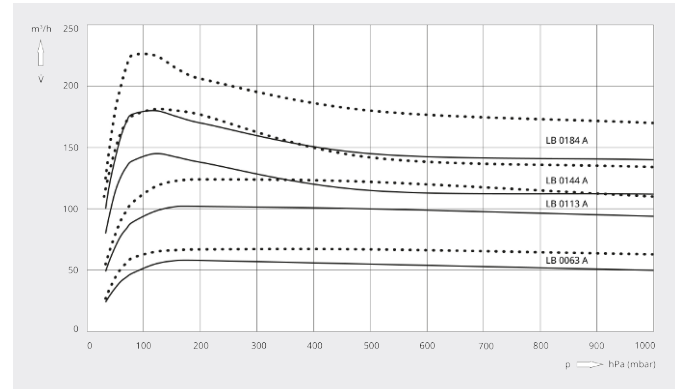

	DOLPHIN LB 0063 A	DOLPHIN LB 0113 A	DOLPHIN LB 0144 A	DOLPHIN LB 0184 A
Nominal pumping speed	60 / 65 m³/h (50 / 60 Hz)	110 / 120 m³/h (50 / 60 Hz)	140 / 180 m³/h (50 / 60 Hz)	180 / 225 m³/h (50 / 60 Hz)
Ultimate pressure	33 hPa (mbar) (50 / 60 Hz)	33 hPa (mbar) (50 / 60 Hz)	33 hPa (mbar) (50 / 60 Hz)	33 hPa (mbar) (50 / 60 Hz)
Nominal motor rating	3 / 4 kW (50 / 60 Hz)	4 kW (50 / 60 Hz)	4 / 5.5 kW (50 / 60 Hz)	5.5 / 7.5 kW (50 / 60 Hz)
Nominal motor speed	1450 / 1750 min ⁻¹ (50 / 60 Hz)	1450 / 1750 min ⁻¹ (50 / 60 Hz)	1450 / 1750 min ⁻¹ (50 / 60 Hz)	1450 / 1750 min ⁻¹ (50 / 60 Hz)
Noise level (ISO 2151)	72 dB(A) (50 / 60 Hz)	72 dB(A) (50 / 60 Hz)	72 dB(A) (50 / 60 Hz)	72 dB(A) (50 / 60 Hz)
Weight approx.	77 kg	78 kg	103 kg	119 kg
Dimensions (L x W x H)	(489 – 664) x 250 x 320 mm	(529 – 704) x 250 x 320 mm	(596 – 762) x 270 x 405 mm	(656 – 822) x 270 x 405 mm
Gas inlet / outlet	DN 40 PN 10 / DN 40 PN 10	DN 40 PN 10 / DN 40 PN 10	DN 40 PN 10 / DN 40 PN 10	DN 40 PN 10 / DN 40 PN 10

DO YOU WANT TO KNOW MORE?

Get in touch with us directly!
sales@busch.com.sg or +65 (0)64 88 08 66



CONTACT FORM



CALL NOW