

DOLPHIN LB 0265-0425 A

Liquid ring vacuum pumps

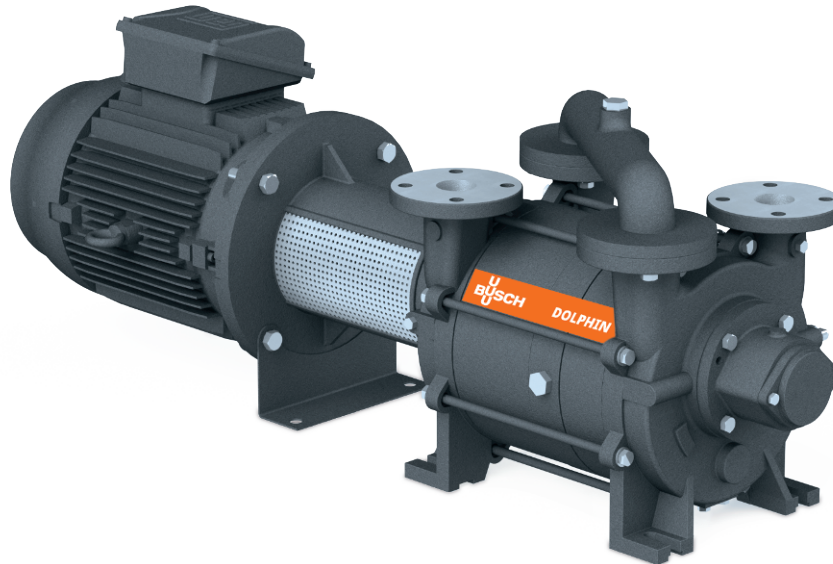

VACUUM SOLUTIONS



Robust

Proven technology, durable two-stage construction

Reliable

Extremely high vapor and particle tolerance

Flexible

Wide range of construction materials, including cast iron (EN-GJL-200), many grades of stainless steel and even titanium, ATEX-certified version available (Cat 1(i)/2(o) IIC T5), operating fluids other than water possible, operation as compressor possible

Accessories, spare parts and options

- Partial or total recirculation systems
- Liquid separator
- Cavitation protection
- Heat exchanger
- Gas ejector
- Wide selection of motors
- Non-return valves
- Vacuum relief valves

DOLPHIN LB 0265-0425 A

Liquid ring vacuum pumps



VACUUM SOLUTIONS

Dimensional drawing

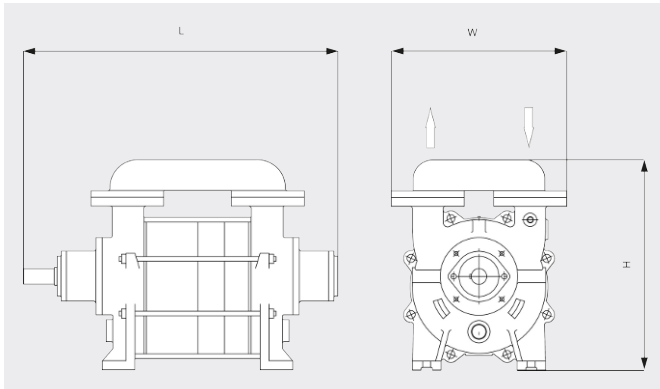

Pumping speed

Air at 20°C. Tolerance: ± 10%

— 50 Hz 60 Hz

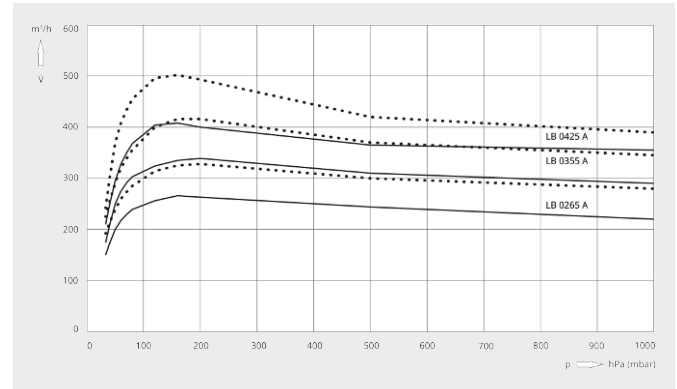

	DOLPHIN LB 0265 A	DOLPHIN LB 0355 A	DOLPHIN LB 0425 A
Nominal pumping speed	260 / 325 m³/h (50 / 60 Hz)	350 / 400 m³/h (50 / 60 Hz)	420 / 500 m³/h (50 / 60 Hz)
Ultimate pressure	33 hPa (mbar) (50 / 60 Hz)	33 hPa (mbar) (50 / 60 Hz)	33 hPa (mbar) (50 / 60 Hz)
Nominal motor rating	7.5 / 11 kW (50 / 60 Hz)	11 / 15 kW (50 / 60 Hz)	15 / 15 kW (50 / 60 Hz)
Nominal motor speed	1450 / 1750 min ⁻¹ (50 / 60 Hz)	1450 / 1750 min ⁻¹ (50 / 60 Hz)	1450 / 1750 min ⁻¹ (50 / 60 Hz)
Noise level (ISO 2151)	75 dB(A) (50 / 60 Hz)	75 dB(A) (50 / 60 Hz)	75 dB(A) (50 / 60 Hz)
Weight approx.	165 kg	183 kg	194 kg
Dimensions (L x W x H)	(707 – 898) x 300 x 472 mm	(767 – 958) x 300 x 472 mm	(807 – 998) x 300 x 472 mm
Gas inlet / outlet	DN 50 PN 10 / DN 50 PN 10	DN 50 PN 10 / DN 50 PN 10	DN 50 PN 10 / DN 50 PN 10

DO YOU WANT TO KNOW MORE?

Get in touch with us directly!
sales@busch.com.sg or +65 (0)64 88 08 66



CONTACT FORM



CALL NOW