

R5 KD 0012/0020 A

Oil-lubricated rotary vane vacuum pumps



VACUUM SOLUTIONS



Compact

Direct-drive construction, reduced height and weight, specially designed for small packaging machines

Reliable

High vapor tolerance, excellent condensation protection, optimum temperature management

Easy servicing

Fast service routine, long service intervals, smooth surface design for easy cleaning

R5 KD 0012/0020 A

Oil-lubricated rotary vane vacuum pumps



VACUUM SOLUTIONS

Dimensional drawing

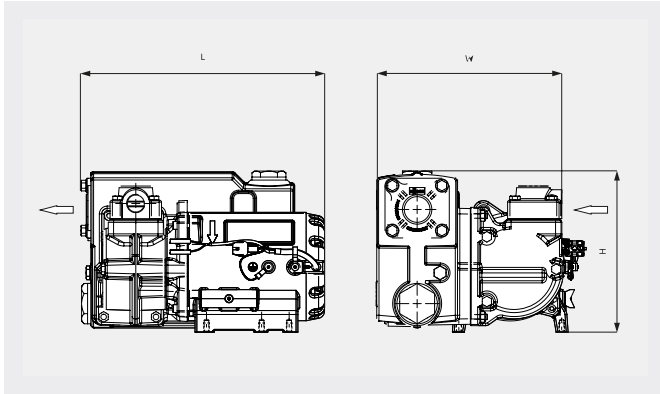

Pumping speed

Air at 20°C. Tolerance: ± 10%

— 50 Hz 60 Hz

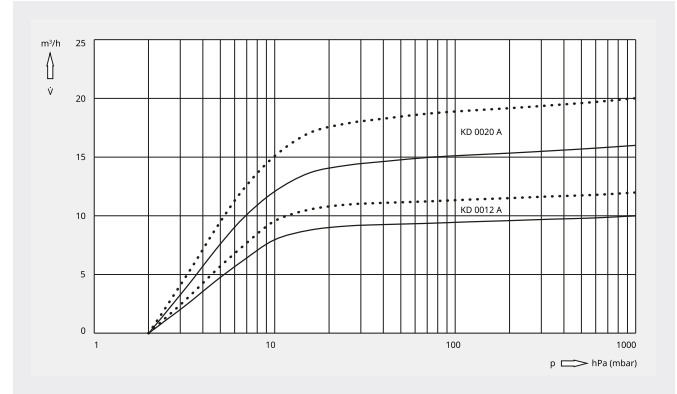

	R5 KD 0012 A	R5 KD 0020 A
Nominal pumping speed	10 / 12 m³/h (50 / 60 Hz)	16 / 20 m³/h (50 / 60 Hz)
Ultimate pressure	2.0 hPa (mbar) (50 / 60 Hz)	2.0 hPa (mbar) (50 / 60 Hz)
Nominal motor rating	0.37 kW (50 / 60 Hz)	0.55 kW (50 / 60 Hz)
Nominal motor speed	3000 / 3600 min ⁻¹ (50 / 60 Hz)	3000 / 3600 min ⁻¹ (50 / 60 Hz)
Noise level (ISO 2151)	59 / 62 dB(A) (50 / 60 Hz)	59 / 62 dB(A) (50 / 60 Hz)
Oil capacity	0.35 l	0.35 l
Weight approx.	14 kg	15 kg
Dimensions (L x W x H)	265 x 215 x 175 mm	265 x 215 x 175 mm
Gas inlet / outlet	G ½"	G ½"

DO YOU WANT TO KNOW MORE?

Get in touch with us directly!
sales@busch.com.sg or +65 (0)64 88 08 66



CONTACT FORM



CALL NOW