

# SAMOS SI 0320/1150 E2

Side channel blowers

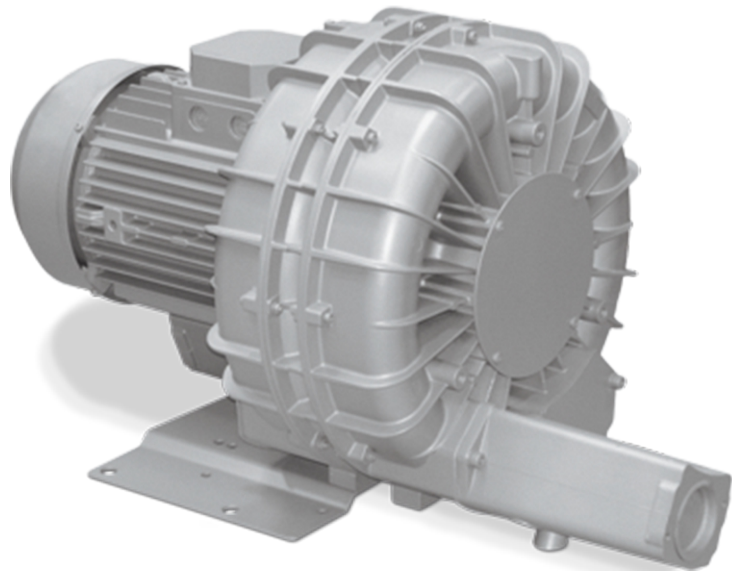

VACUUM SOLUTIONS



## Reliable

Robust construction, effective air cooling, long lifetime, nearly maintenance-free, dry and contact-free operating principle, high differential pressures thanks to two compression stages, protection against overheating

## Flexible

Vacuum or overpressure operation, horizontal and vertical installation

## Quiet

Low noise level, fully enclosed unit, internal silencers

### Accessories

- Vacuum relief valves
- Pressure relief valves
- Additional silencers

# SAMOS SI 0320/1150 E2

Side channel blowers



VACUUM SOLUTIONS

Dimensional drawing

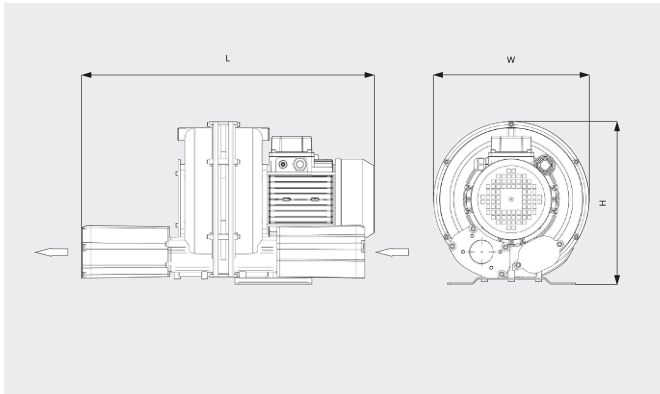

Pumping speed/Volume flow  
Air at 20°C. Tolerance: ± 10%

— 50 Hz ..... 60 Hz

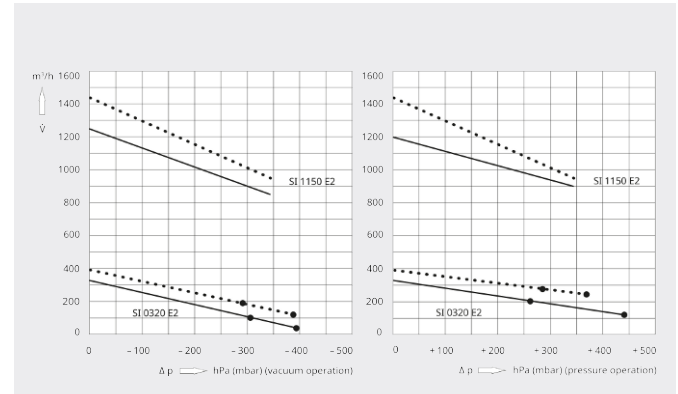

	SAMOS SI 0320 E2	SAMOS SI 0320 E2	SAMOS SI 1150 E2
<b>Nominal pumping speed/volume flow</b>	330 / 395 m <sup>3</sup> /h (50 / 60 Hz)	330 / 395 m <sup>3</sup> /h (50 / 60 Hz)	1200 / 1440 m <sup>3</sup> /h (50 / 60 Hz)
<b>Max. differential pressure (vacuum version)</b>	-315 / -295 hPa (mbar) (50 / 60 Hz)	-390 / -380 hPa (mbar) (50 / 60 Hz)	-345 hPa (mbar) (50 / 60 Hz)
<b>Max. differential pressure (overpressure version)</b>	+260 / +275 hPa (mbar) (50 / 60 Hz)	+440 / +370 hPa (mbar) (50 / 60 Hz)	+345 hPa (mbar) (50 / 60 Hz)
<b>Nominal motor rating</b>	4.0 / 4.6 kW (50 / 60 Hz)	5.5 / 6.3 kW (50 / 60 Hz)	20.0 / 25.2 kW (50 / 60 Hz)
<b>Nominal motor speed</b>	3000 / 3600 min <sup>-1</sup> (50 / 60 Hz)	3000 / 3600 min <sup>-1</sup> (50 / 60 Hz)	3000 / 3600 min <sup>-1</sup> (50 / 60 Hz)
<b>Noise level (ISO 3744)</b>	77 / 81 dB(A) (50 / 60 Hz)	77 / 81 dB(A) (50 / 60 Hz)	80 dB(A) (50 / 60 Hz)
<b>Weight approx.</b>	60 kg	60 kg	240 kg
<b>Dimensions (L x W x H)</b>	703 x 395 x 415 mm	703 x 395 x 415 mm	1352 x 615 x 631 mm
<b>Gas inlet / outlet</b>	G 2" / G 2"	G 2" / G 2"	G 4" / G 4"

## DO YOU WANT TO KNOW MORE?

Get in touch with us directly!  
sales@busch.com.sg or +65 (0)64 88 08 66



CONTACT FORM



CALL NOW