

DOLPHIN LM 0530/0800 A

Liquid ring vacuum pumps and compressors



VACUUM SOLUTIONS



Robust

Proven technology, durable single-stage construction, corrosion-free stainless steel impeller, direct flange-mounted motor, no base frame required, integrated flow channel

Reliable

Extremely high vapor and particle tolerance, optimized gas flow

Flexible

Choice of cast iron (EN-GJL-200) or 316 grade stainless steel material housings, ATEX-certified version available (Cat 1(i/o) IIC T4), operating fluids other than water possible

Accessories

- Modular pumpsets, configured for once-through, partial or total recirculation of the operating fluid
- Liquid separator
- Cavitation protection
- Heat exchanger
- Gas ejector
- Wide selection of motors
- Non-return valves
- Vacuum relief valves
- Variable speed drive

DOLPHIN LM 0530/0800 A

Liquid ring vacuum pumps and compressors



VACUUM SOLUTIONS

Dimensional drawing

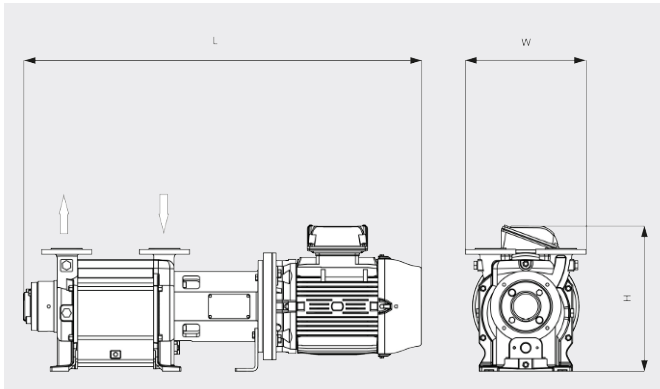

Pumping speed

Dry air at 20°C. Operating fluid water 15°C. Tolerance: - 10%, in accordance with HEI and Pneurop 6612

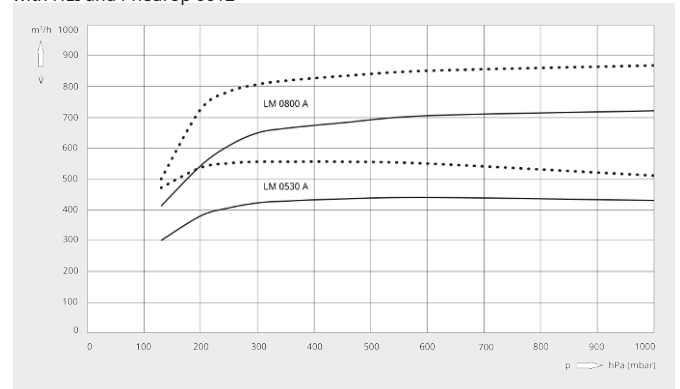

	DOLPHIN LM 0530 A	DOLPHIN LM 0800 A
Nominal pumping speed	440 / 556 m³/h (50 / 60 Hz)	722 / 867 m³/h (50 / 60 Hz)
Ultimate pressure	130 hPa (mbar) (50 / 60 Hz)	130 hPa (mbar) (50 / 60 Hz)
Max. overpressure	1.5 bar(g) (50 / 60 Hz)	1.5 bar(g) (50 / 60 Hz)
Nominal motor rating	11.0 / 15.0 kW (50 / 60 Hz)	18.5 / 22.0 kW (50 / 60 Hz)
Nominal motor speed	1450 / 1750 min ⁻¹ (50 / 60 Hz)	1450 / 1750 min ⁻¹ (50 / 60 Hz)
Noise level (ISO 2151)	72 / 73 dB(A) (50 / 60 Hz)	75 / 76 dB(A) (50 / 60 Hz)
Weight approx.	317 kg	340 kg
Dimensions (L x W x H)	1297 x 396 x 478 mm	1457 x 425 x 506 mm
Gas inlet / outlet	DN 50 PN 10 / DN 50 PN 10	DN 65 PN 10 / DN 65 PN 10

DO YOU WANT TO KNOW MORE?

Get in touch with us directly!
sales@busch.com.sg or +65 (0)64 88 08 66



CONTACT FORM



CALL NOW