

DOLPHIN VL 0430-0750 A

Partial Recirculation

Liquid ring vacuum pump units



VACUUM SOLUTIONS



Robust

Proven technology, reliable operation, corrosion-free stainless steel impeller, extremely high vapor and particle tolerance, part of the operating fluid is recirculated, fresh liquid introduced in sufficient quantity to maintain proper temperature

All-in-One

Unit with base frame, operating fluid separator, control system, including inlet check valve, fresh liquid supply kit, level indicator with switches, temperature and pressure indicators and cavitation protection

Flexible

Choice of cast iron (EN-GJL-200) or 316 grade stainless steel material housings, ATEX-certified version available (Cat. 1 (i/o) IIC, T4), operating fluids other than water possible

DOLPHIN VL 0430-0750 A Partial Recirculation

Liquid ring vacuum pump units



VACUUM SOLUTIONS

Dimensional drawing

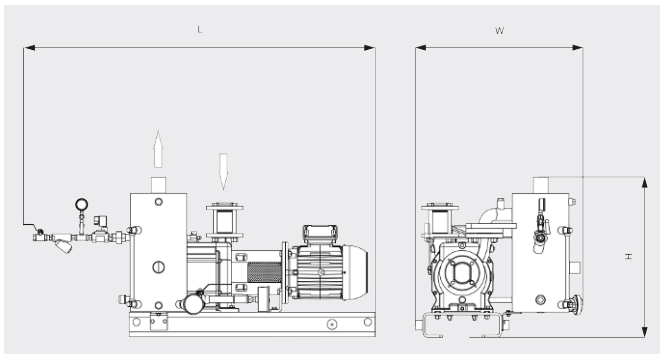

Dimensional drawing

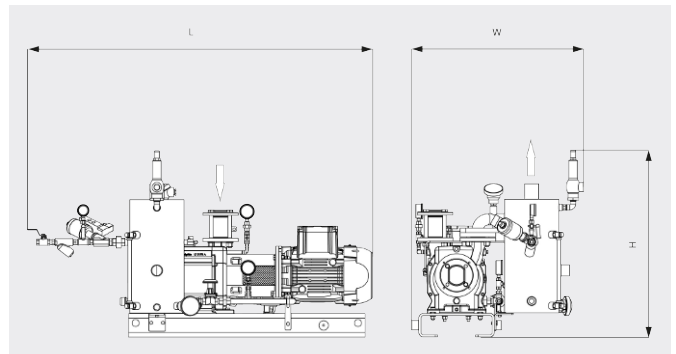

	DOLPHIN VL 0430 A Partial Recirculation	DOLPHIN VL 0510 A Partial Recirculation	DOLPHIN VL 0630 A Partial Recirculation	DOLPHIN VL 0750 A Partial Recirculation
Nominal pumping speed	340 / 419 m ³ /h (50 / 60 Hz)	430 / 515 m ³ /h (50 / 60 Hz)	498 / 574 m ³ /h (50 / 60 Hz)	600 / 710 m ³ /h (50 / 60 Hz)
Ultimate pressure	33 hPa (mbar) (50 / 60 Hz)	33 hPa (mbar) (50 / 60 Hz)	33 hPa (mbar) (50 / 60 Hz)	33 hPa (mbar) (50 / 60 Hz)
Nominal motor rating	11.0 / 15.0 kW (50 / 60 Hz)	11.0 / 15.0 kW (50 / 60 Hz)	15.0 / 22.0 kW (50 / 60 Hz)	18.5 / 30.0 kW (50 / 60 Hz)
Weight approx.	435 / 513 kg (Safe / ATEX)	465 / 543 kg (Safe / ATEX)	541 / 612 kg (Safe / ATEX)	593 / 685 kg (Safe / ATEX)
Dimensions (L x W x H)	1524 x 869 x 947 / 1642 x 936 x 1066 mm (Safe / ATEX)	1591 x 870 x 947 / 1702 x 936 x 1066 mm (Safe / ATEX)	1817 x 955 x 962 / 1811 x 1045 x 1243 mm (Safe / ATEX)	1822 x 955 x 962 / 1903 x 1045 x 1243 mm (Safe / ATEX)
Gas inlet / outlet	G 2" / R 3"	G 2" / R 3"	G 2½" / R 4"	G 2½" / R 4"

DO YOU WANT TO KNOW MORE?

Get in touch with us directly!
sales@busch.com.sg or +65 (0)64 88 08 66



CONTACT FORM



CALL NOW