

DOLPHIN VL 0430-0750 A Total Recirculation

Liquid ring vacuum pump units

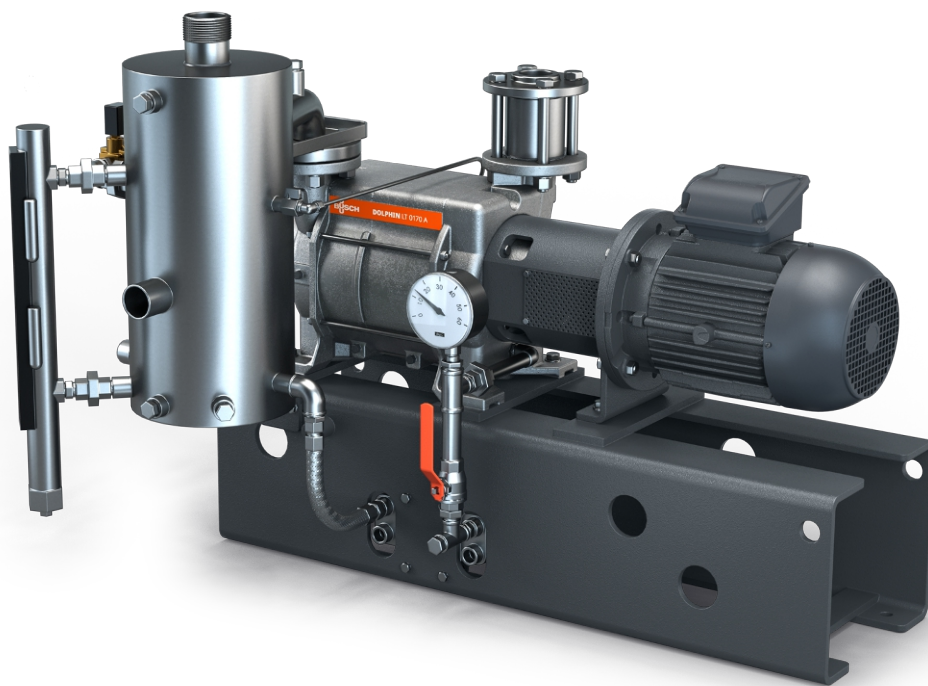

Robust

Proven technology, reliable operation, corrosion-free stainless steel impeller, extremely high vapor and particle tolerance, choice of cast iron (EN-GJL-200) or 316 grade stainless steel material housings, ATEX-certified version available (Cat. 1 (i/o) IIC, T4)

All-in-One

Unit with base frame, operating fluid separator, heat exchanger, control system, including inlet check valve, fresh liquid supply kit, level indicator with switches, temperature and pressure indicators and cavitation protection

Efficient

Full recirculation of operating fluid, low operating fluid consumption, recovery of condensed vapors and process gases, isolation of cooling liquid from operating fluid, operating fluids other than water possible

DOLPHIN VL 0430-0750 A Total Recirculation

Liquid ring vacuum pump units



VACUUM SOLUTIONS

Dimensional drawing

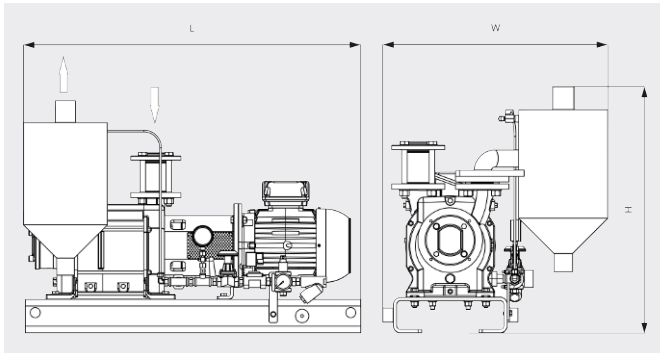

Dimensional drawing

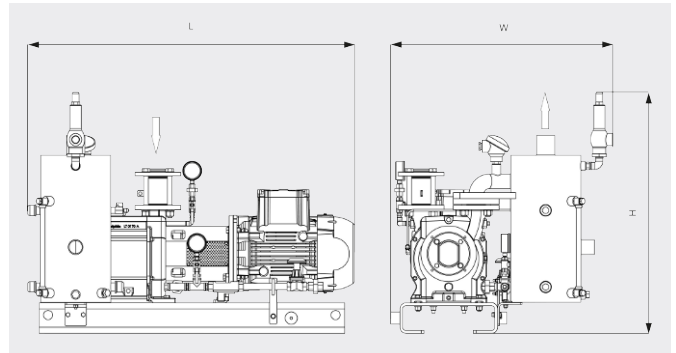

	DOLPHIN VL 0430 A Total Recirculation	DOLPHIN VL 0510 A Total Recirculation	DOLPHIN VL 0630 A Total Recirculation	DOLPHIN VL 0750 A Total Recirculation
Nominal pumping speed	340 / 419 m ³ /h (50 / 60 Hz)	430 / 515 m ³ /h (50 / 60 Hz)	498 / 574 m ³ /h (50 / 60 Hz)	600 / 710 m ³ /h (50 / 60 Hz)
Ultimate pressure	33 hPa (mbar) (50 / 60 Hz)	33 hPa (mbar) (50 / 60 Hz)	33 hPa (mbar) (50 / 60 Hz)	33 hPa (mbar) (50 / 60 Hz)
Nominal motor rating	11.0 / 15.0 kW (50 / 60 Hz)	11.0 / 15.0 kW (50 / 60 Hz)	15.0 / 22.0 kW (50 / 60 Hz)	18.5 / 30.0 kW (50 / 60 Hz)
Weight approx.	474 / 551 kg (Safe / ATEX)	505 / 579 kg (Safe / ATEX)	583 / 646 kg (Safe / ATEX)	641 / 724 kg (Safe / ATEX)
Dimensions (L x W x H)	1571 x 853 x 1129 / 1645 x 946 x 1248 mm (Safe / ATEX)	1585 x 894 x 1129 / 1704 x 973 x 1248 mm (Safe / ATEX)	1750 x 973 x 1144 / 1812 x 973 x 1431 mm (Safe / ATEX)	1827 x 973 x 1144 / 1909 x 1059 x 1431 mm (Safe / ATEX)
Gas inlet / outlet	G 2" / R 3"	G 2" / R 3"	G 2½" / R 4"	G 2½" / R 4"

DO YOU WANT TO KNOW MORE?

Get in touch with us directly!
sales@busch.com.sg or +65 (0)64 88 08 66



CONTACT FORM



CALL NOW