

DOLPHIN VL 0530-0800 A

Continuous Flow

Liquid ring vacuum pump units



VACUUM SOLUTIONS



Robust

Proven technology, reliable operation, corrosion-free stainless steel impeller, extremely high vapor and particle tolerance, automatic solenoid valve for control of operating fluid flow from main supply

All-in-One

Unit with base frame, operating fluid separator, control system, including inlet check valve, fresh liquid supply kit, level indicator (ATEX only), temperature sensor (ATEX only) and pressure indicators and cavitation protection

Flexible

Choice of cast iron (EN-GJL-200) or 316 grade stainless steel material housings, ATEX-certified version available (Cat. 1 (i/o) IIC, T4), operating fluids other than water possible

DOLPHIN VL 0530-0800 A Continuous Flow

Liquid ring vacuum pump units



VACUUM SOLUTIONS

Dimensional drawing

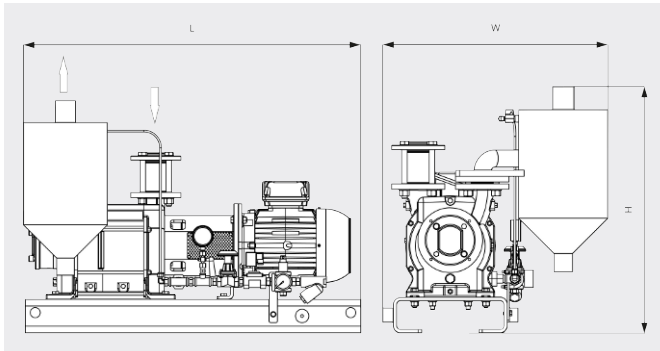

Dimensional drawing

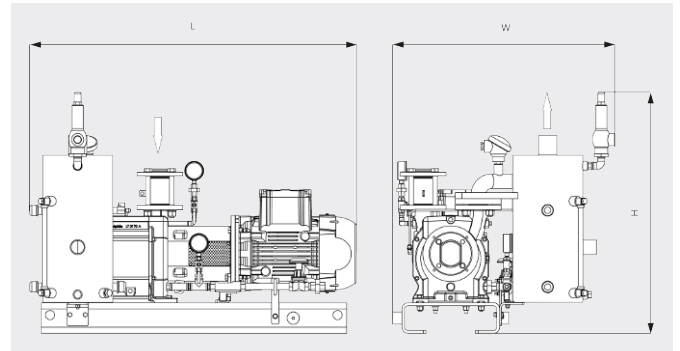

	DOLPHIN VL 0530 A Continuous Flow	DOLPHIN VL 0800 A Continuous Flow
Nominal pumping speed	405 / 551 m ³ /h (50 / 60 Hz)	722 / 867 m ³ /h (50 / 60 Hz)
Ultimate pressure	130 hPa (mbar) (50 / 60 Hz)	130 hPa (mbar) (50 / 60 Hz)
Nominal motor rating	11.0 / 15.0 kW (50 / 60 Hz)	18.5 / 22.0 kW (50 / 60 Hz)
Weight approx.	451 / 612 kg (Safe / ATEX)	518 / 612 kg (Safe / ATEX)
Dimensions (L x W x H)	1383 x 815 x 854 / 1507 x 1054 x 1184 mm (Safe / ATEX)	1501 x 875 x 932 / 1676 x 1054 x 1184 mm (Safe / ATEX)
Gas inlet / outlet	G 2" / R 3"	G 2½" / R 4"

DO YOU WANT TO KNOW MORE?

Get in touch with us directly!
sales@busch.com.sg or +65 (0)64 88 08 66



CONTACT FORM



CALL NOW