

Installation and Maintenance Instructions

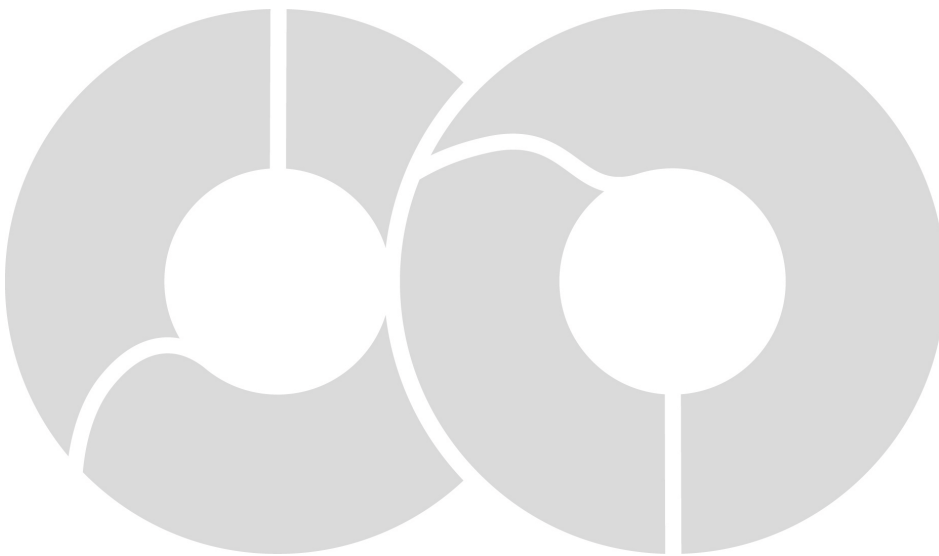

Screw Vacuum Pumps

COBRA BC 0100 F PE

Get technical data,
instruction manuals,
service kits



VACUUM APP

Table of contents

Preface	2
BC 0100 F PE pump description	3
Product description	4
Use	4
Operating principle	4
Oil circuit	5
Cooling	5
Nitrogen system	5
Optional functions/ Use of available accessories	5
On/ Off switch	5
Versions	5
Safety	5
Intended use	5
Safety information	5
Noise emission	6
Maintenance clearance	6
Electrical safety	6
Types of Electrical Work	6
Type 1.	6
Type 2.	6
Type 3.	6
Type 4.	6
Lock Out/ Tag Out procedure (Type 1 of electrical work)	6
Safety Lockout procedure	6
Emergency off circuit description	6
Safety interlock description	7
Position of the pump gravity center	7
Installation of the vacuum pump in a seismic zone	7
Information over the lubricants	7
Oil	7
Decommissioning procedure	8
Appliance after warehousing	8
Lock out/ Tag out for hydraulics and pneumatics	8
Lock Out/ Tag Out procedure (Type 1 of electrical work)	8
Lock Out/ Tag Out procedure	8
Safety Lockout procedure	9
Transport	9
Transport in packed state	9
Transport in unpacked state	9
Storage	9
Temporary storage	9
Removal of the pump	9
Preservation	9
Start-up of the vacuum pump after storage:	9
Installation and start-up	10
Necessary installation instructions	10
Installation site and installation	10
Inlet connection	10
Discharge connection	11
Cooling water connection	11
Nitrogen connection	11
Electrical connection/ Checks	11
Power wiring connections	11
Power connector on vacuum pump front side	11
Installation	11
Mounting	11
Electrical connection	11
Equipment connections (with options)	12
Connection of the lines/ pipes	12
Oil filling	12
Checking the direct cooling	13
Saving the operating parameters	13
Recommendations on operation	13
Application	13
Switching the vacuum pump on/off	14
First start-up of the system	14
Switching the system off	14
Maintenance	14
Maintenance program	14
Weekly:	14
Monthly:	15
Yearly:	15
Every 16 000 hours of operation, at the latest after 4 years:	15

Lock Out/ Tag Out procedure	15
Safety Lockout procedure	15
Checking the oil	15
Checking the oil level	15
Refilling oil	15
Checking the colour of the oil	15
Oil change	16
Draining used oil	16
Filling in new oil	16
Checking the cooling water	16
Checking the cooling water flow	16
Checking the nitrogen	16
Checking the nitrogen flow	16
Checking the current consumption	16
Checking the sound absorber (accessory)	16
Checking the leak-protection non-return valve (accessory)	16
Overhaul	17
Removal from service	17
Temporary removal from service	17
Recommissioning	17
Dismantling and disposal	17
Oil type/ quantity	18
Oil type	18
Oil quantity	18
Technical data	19
EU-Declaration of Conformity	20
UK-Declaration of Conformity	21

Preface

Congratulations on your purchase of the Busch vacuum pump. With watchful observation of the field's requirements, innovation and steady development Busch delivers modern vacuum and pressure solutions worldwide.

These operating instructions contain information for:

- product description,
- safety, transport,
- storage,
- installation and commissioning
- maintenance, overhaul and
- troubleshooting of the vacuum pump.

For the purpose of these instructions, "handling" the vacuum pump means the transport, storage, installation, commissioning, influence on operating conditions, maintenance, troubleshooting and overhaul of the vacuum pump.

Prior to handling the vacuum pump these operating instructions shall be read and understood. If anything remains to be clarified please contact your Busch representative. Keep these operating instructions and, if applicable, other pertinent operating instructions available on site.

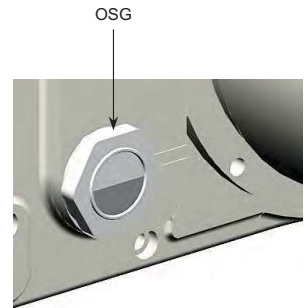

BC 0100 F PE pump description



- IN Inlet connection
- OUT Discharge connection
- OPF Oil fill plug
- OSG Oil sight glass
- PRV Nitrogen pressure reducer
- PS Pressure switch (Discharge)
- CWC Cooling water connection
- CWR Cooling water regulating valve
- CWM Cooling water flow meter
- NC Nitrogen connection
- NRV Nitrogen regulating valve
- MAN Manometer
- ES Emergency stop
- EC Electrical connection
- TSA Resistance thermometer
- CP Control panel
- CPC Control panel connection
- MB Main breaker
- EB Eye bolt
- RC Remote control
- MV Nitrogen solenoid valve

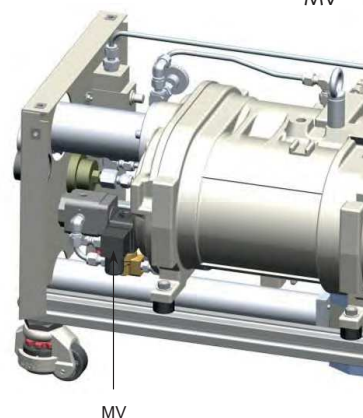
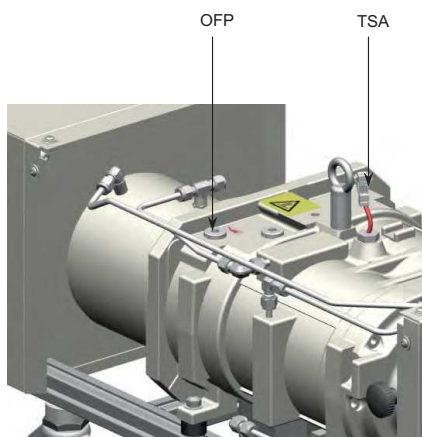

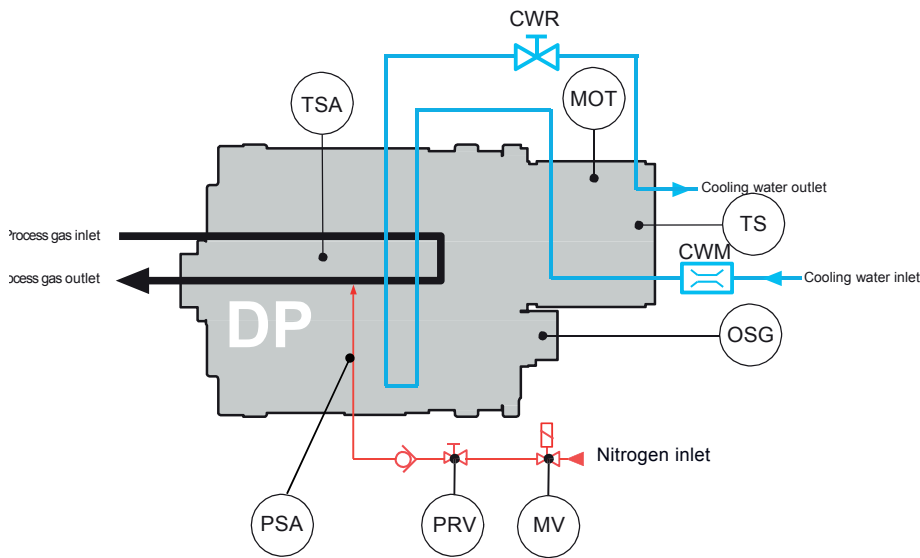

- CWR Cooling water regulating valve
- OSG Oil sight glass
- CWM Cooling water flow meter
- TSA Resistance thermometer
- MOT Motor
- TS Temperature switch (motor)
- PRV Nitrogen pressure reducer
- MV Nitrogen solenoid valve
- PSA Outlet pressure sensor

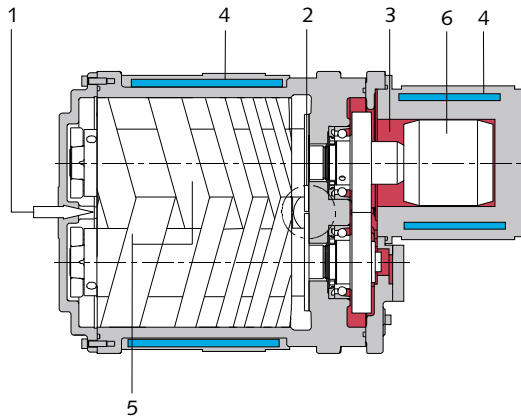

- 1 Inlet
- 2 Discharge
- 3 Oil
- 4 Cooling water
- 5 Screw rotors
- 6 Temperature switch (motor)

Product description

Use

The COBRA BC vacuum pumps are designed for use in the field of microelectronics and similar industries.

They can be used to suck gases and gas mixtures.



WARNING

When using toxic, inflammable and/or explosive gases, make sure that the system corresponds in design to applicable local and national safety regulations and that all applicable safety measures are followed.

All product-specific safety regulations must be observed.

Solid particles must not get into the vacuum pump. Procedural errors can result in the pump sucking in a certain quantity of liquid. If the pump has sucked in liquid, a short drying time is necessary at the end of the procedure.

The allowed maximum inlet gas temperature depends on the inlet pressure and the type of gas: the lower the inlet pressure (Pa), the higher the drawn gas temperature (TGas) can be.

The following indicative values for air can be considered:

- Pa > 50 mbar, TGas < 80°C
- Pa < 50 mbar, TGas < 200°C

The vacuum pump is intended for use in a potentially non-explosive environment.

As far as temperature is concerned, the vacuum pump is suitable for evacuation of a 300 liters tank. The vacuum pump is not suitable for continuous duty at a pressure more or equal than 150 (hPa) mbar. Caution, the operating cycle of 150 (hPa) mbar must not exceed more than 5 min. For other applications, contact your Busch representative.

- Maximum inlet pressure: 1 bar (abs).
- With vacuum pump running at full speed, do not expose to inlet pressure > 300 (hPa) mbar.

The vacuum pump is tight down to ultimate pressure.

Operating principle

The COBRA BC 0100 F PE vacuum pumps are COBRA NW screw vacuum pumps with cooling water and nitrogen circuits.

The COBRA NW screw vacuum pumps operate according to the principle of screw pumps. Two parallel screws (5) rotate in opposite directions in the pump body. Entering gases are trapped between the

flights of the screws and the pump body. The gases are conveyed by the rotation of the screws to the exhaust, where they are discharged.

The COBRA NW screw vacuum pumps are driven by water-cooled motors.

Oil circuit

Since the complete operating principle works without contact, no oil circuit is needed in the work area.

Cooling

The vacuum pump is cooled by

- a cooling water circuit (4) in the cylinder and motor. The cooling water flow is preset at 1 l/min at the factory and can be adjusted with valve CWR. This cooling water circuit is used to cool the motor of the pump, the frequency inverter and also the body of the NW pump.

NOTE: The COBRA BC vacuum pumps are always delivered without oil and without cooling water. Operation without these coolants can result in damage to the vacuum pump.

Nitrogen system

With a pressure of 4,0 bar, the flow is around 25 l/min.

Optional functions/ Use of available accessories

A pressure sensor mounted at the exhaust, controls the overpressure at the exhaust. If overpressure is above 0,1 bar, pressure switch gives a warning signal. If overpressure is above 0,2 bar an alarm is generated. Status of the pump depends on the alarm function set by user (factory setting: None, pump continues running with an alarm).

A temperature sensor mounted on the cylinder, measures the temperature inside the cylinder.

A silencer or sound absorber (accessory) at the exhaust reduces the noise of the pump and collects any condensate.

A leak-protection non-return valve (optional) at the exhaust traps the condensate in the pump when the pump is switched off.

The LCD controller processes the data of the sensors (see chapter "Communication with the equipment") as follows:

- discharge pressure
- temperature in the cylinder
- current
- nitrogen flow rate
- cooling water flow rate

The data process with the C.M.S. (Central Monitoring System) (accessory) has the same function as the LCD controller (see operating instructions of Central Monitoring System).

On/ Off switch

The vacuum pump is delivered with on/ off switch.

Versions

Further vacuum pump descriptions state the nominal displacement and the design level.

Example: BC 0100 F PE

BC = standard version

0100 = 100 m³/h

F PE = Design

Safety

Intended use

DEFINITION: To rule out any misunderstanding, the term "handling" of the vacuum pump covers transport, storage, installation and operation of the pump as well as effects on operating states and troubleshooting on the vacuum pump.

The vacuum pump is intended for industrial use. It may only be operated by qualified personnel.

The different application possibilities and limit values for operation described in "Product description" and "Installation requirements" must be observed by the manufacturer of the system into which the vacuum pump is to be integrated and by users.

The need for personal safety regulations depends in principle on the type of use. The operator must provide the users with the necessary means and must inform his personnel about the dangers emanating from the processed product.

The operator of the vacuum pump must observe the safety regulations and must train and instruct his personnel accordingly.

Local regulations regarding the motors and electric control elements must be observed when installing the pump in potentially explosive environments.

The maintenance instructions must be followed and observed.

These installation and maintenance instructions must be read and understood before the vacuum pump is used. If you have any doubts, contact your Busch representative.

Safety information

The vacuum pump is designed and manufactured in compliance with the latest technical standards and safety regulations. Nevertheless an element of residual risk remains.

Various safety instructions are to be found in this handbook and on the pump. These instructions must be followed. You can recognise these instructions by the signal words DANGER, WARNING and CAUTION, which are defined as follows:



DANGER

Disregard of this safety note will always lead to accidents with potentially fatal injuries and serious damages.



WARNING

Disregard of this safety note may lead to accidents with potentially fatal injuries and serious damages.



CAUTION

Disregard of this safety note will always lead to accidents with minor injuries and damages to property.



Noise emission

Refer to the table "Technical data" for the permissible noise level in free field conditions according to EN ISO 2151.



CAUTION

The intensity of the noise of the vacuum pump is higher within a certain area of the pump.

Risk of hearing damage.

Users must wear ear protection when spending a longer period of time in the vicinity of a non-insulated vacuum pump.

Maintenance clearance

Before any maintenance action, ensure a maintenance clearance around the pump of min. 610 [mm].

Electrical safety

Types of Electrical Work

The following are the four types of electrical work defined by the SEMI S2, latest version, guideline:

Type 1

Equipment is fully deenergized.

Type 2

Equipment is energized. Energized circuits are covered or insulated.

NOTE : Type 2 work includes tasks where the energized circuits are or can be measured by placing probes through suitable openings in the covers or insulators.

Type 3

Equipment is energized. Energized circuits are exposed and inadvertent contact with uninsulated energized parts is possible. Potential exposures are no greater than 30 volts rms, 42.4 volts peak, 60 volts dc or 240 volt-amp in dry locations.

Type 4

Equipment is energized. Energized circuits are exposed and inadvertent contact with uninsulated energized parts is possible. Potential

exposures are greater than 30 volts rms, 42.4 volts peak, 60 volts dc, or 240 volt-amp in dry locations. Potential exposures to radio-frequency currents, whether induced or via contact, exceed the limits in Table A5-1 of Appendix 5 (SEMI S2 guideline).

Lock Out/ Tag Out procedure (Type 1 of electrical work)

- Stop the pump with the remote control or with the stop button (press on STOP button during 10s)
- Press on emergency stop button
- Switch off the main circuit breaker
- Switch off the customer's power supply
- Switch off the water and nitrogen quick connections (inlet first, then outlet)
- Put the label or warning board "Maintenance processing" on or next to the pump

Safety Lockout procedure

- Take off the label or warning board "Maintenance processing"
- Check the cooling liquid and oil levels according to the chapters "Checking the oil level" and "Checking the cooling liquid level"
- Switch on the main circuit breaker
- Release the emergency stop button
- Switch on the water and nitrogen quick connections (outlet first, then inlet)
- Start the pump with the remote control (press on START button)

Emergency off circuit description

- The Emergency off circuit may be opened by pressing on emergency stop button, or the thermal protection B11. If one of the two elements show, then the pump will immediately stop. The PLC will remain energized to save the pump status.
- If the emergency stop button was pressed, check the start up of the pump then release this button to restart the pump. Press on Start button on the remote control, the pump will restart.
- If ok, check the wiring system from the terminal box motor to the KDP1 contactor. If ok, call the BUSCH Semicon service team in charge of the maintenance of the pumps.

- Switch on the main disconnect switch, then release the emergency stop button. Restart the pump by pressing on Start button on the remote control. If the pump does not start, press on emergency stop button, switch off and padlock the main disconnect switch, switch off the customer's power supply and put the label "maintenance processing". Call the BUSCH Semicon service team in charge of the maintenance of the pumps.
- If the external thermal protection B11 is engaged, check that the water flow shows 1l/min on the flowmeter. If not, set the water flow at 1 l/min according to the instruction (see chapter "Checking the cooling liquid flow"). Check the wiring system of the thermal protection by opening the side face (Type 3 of electrical work). Wait a few hours for the cooling of the protection, then press on Start button to restart the pump.

Safety interlock description

Interlock event	Sensor	Response	
Emergency Stop	EMO S/W	EMO Button Pushed during pump running	H
Motor overcurrent	Frequency inverter	Inverter default and remove power to motor	S
Motor overtemperature (t° > 150°C)	Thermo switch B1 (klixon)	Contactors open and remove power to motor	S
Discharge overpressure (option)	Pressure sensor B4	Depends on alarm function set in the PLC for overpressure Set at factory: None ie. the pump continues running with alarm	S
Cylinder overtemperature (option)	Temperature sensor B6	Depends on alarm function set in the PLC for cylinder temperature Set at factory: General Stop ie. the contactors open and remove power to motor	S
Cooling water flow low	Water flowmeter B2	Depends on alarm function set in the PLC for water flow Set at factory: General Stop ie. the contactors open and remove power to motor	S
Nitrogen flow to low	Nitrogen flowmeter B3	Depends on alarm function set in the PLC for nitrogen flow Set at factory: None ie. the pump continues running with alarm	S

H= Hardware, S= Software

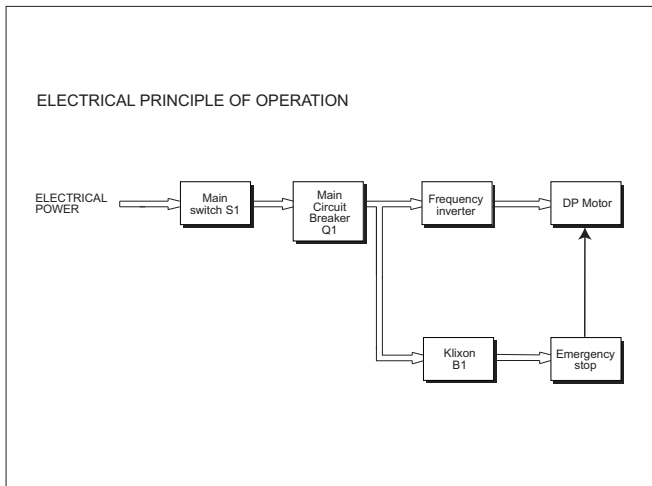

Position of the pump gravity center

- The gravity center of the BC 0100 F PE pump is determined according to the drawing

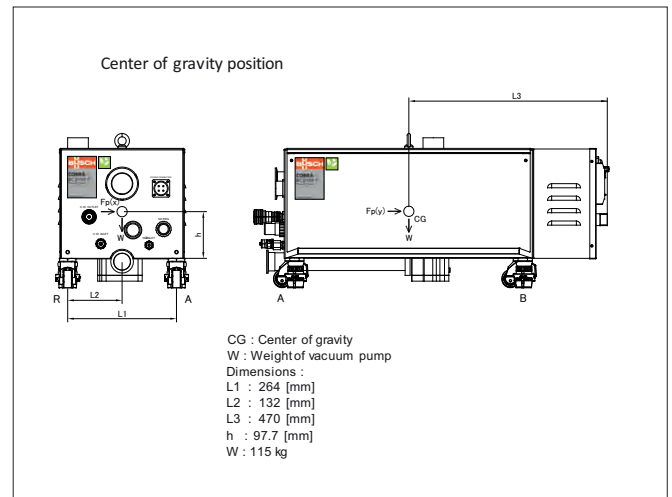

Installation of the vacuum pump in a seismic zone

- Convey the pump to its final location with a pallet truck before removing it from its support
- Unscrew the fixing screws of the pump on the transport pallet and remove the machine from its support with an appropriate lifting system by using the lifting brackets made for this purpose

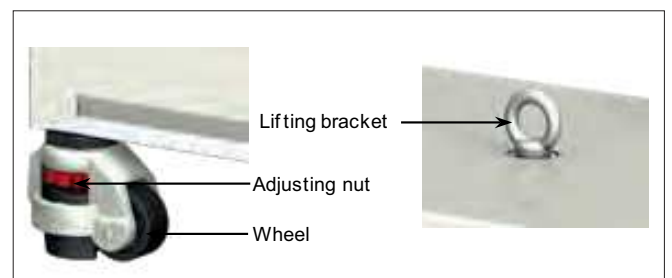

- Check that the wheels no longer touch the ground



CAUTION

The vacuum pump is fixed to the ground with four M10 screws, one screw per bracket. The fixing screw must stand a 1200 N tensile force (per bracket). The final user must adapt the type of screws depending on the ground material.

Information over the lubricants

Oil

Busch YLC 250 B n°. -art. 0831 131 004 (0.5l of Busch YLC 250 B)

Quantity: BC 0100 F PE : 0,12 l

Replacement: After 16'000 h (see Maintenance chapter, page 14)

Decommissioning procedure

When the product arrives at the end of the lifetime, it is necessary to proceed to the decontamination of the vacuum pump



WARNING

Any disassembly of the vacuum pump should only be carried out by staff trained for this purpose. Before disassembly, the user of the vacuum pump should complete a form or "Declaration about absence of danger" which indicates any dangers and corresponding actions.

Without this form duly completed and signed by a legally responsible person, the pump should not be disassembled.

- Proceed to disassembly of the vacuum pump. Please make sure to wear a personal protective equipment (PPE) prior to any intervention on the vacuum pump. Some residue may remain inside.
- Proceed to decommissioning of the different parts according to the current local and national laws

Appliance after warehousing

Prior to reoperate a vacuum pump which remained outside the buiding for a certain period of time, make sure to let it stand at ambient temperature in a room for a whole day.

Lock out/ Tag out for hydraulics and pneumatics

- ◆ Hydraulics: cooling water
- ◆ Pneumatics: nitrogen

Lock Out/ Tag Out procedure (Type 1 of electrical work)

- Stop the pump with the remote control (press on STOP button during 10s)
- Press on emergency stop button
- Switch off the main breaker
- Switch off the customer's power supply
- Switch off the water and nitrogen quick connections (inlet first, then outlet)
- Put the label or warning board "Maintenance processing" on or next to the pump

The end user is responsible for providing energy isolation capabilities on the water and nitrogen

Lock Out/ Tag Out procedure

- Stop the pump with the remote control (press on STOP button during 10s)
- Press on emergency stop button
- Switch off the main breaker
- Switch off the customer's power supply
- Switch off the water and nitrogen quick connections (inlet first, then outlet)

Dimensions drawing

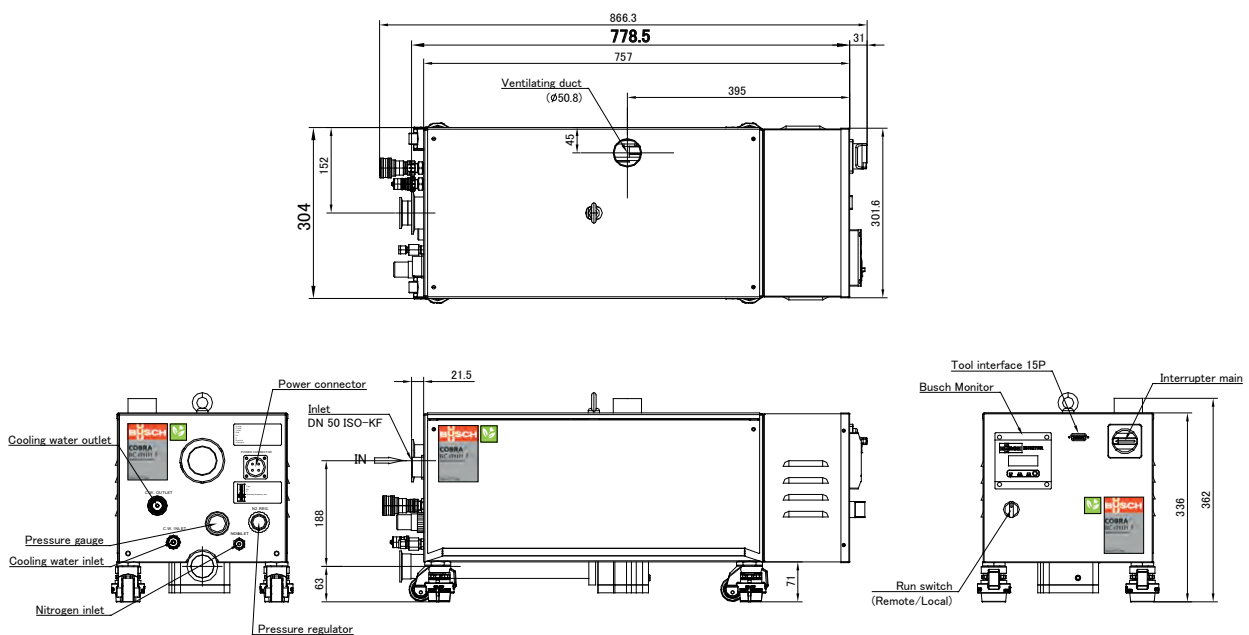

- Put the label or warning board "Maintenance processing" on or next to the pump

Safety Lockout procedure

- Take off the label or warning board "Maintenance processing"
- Check the oil level according to the chapters "Checking the oil level"
- Switch on the main breaker
- Release the emergency stop button
- Switch on the water and nitrogen quick connections (outlet first, then inlet)
- Start the pump with the remote control (press on START button)



Transport

The COBRA BC vacuum pumps are tested and checked in our factory before careful packing. Check the packaging for transport damage when the goods arrive. The pump can withstand temperatures between -25°C and +55°C during transport.

Transport in packed state



Packed on a pallet, the vacuum pump can be moved with a hand forklift truck.

Transport in unpacked state

CAUTION

Do not work, walk or stand under suspended loads.

CAUTION

Please check out the weight of the vacuum pump before lifting it up (see "Technical Data").

Use adequate lifting gear for this.

NOTE: The suspension eyes are located at about the centre-of-gravity of the vacuum pump. If the vacuum pump is equipped with accessories that could influence the centre-of-gravity, this must be taken into account when lifting and a belt must additionally be attached to a specific point.

- Fasten the hoist to the suspension eye on the cylinder
- Use a hoist that is equipped with a hook and safety lock
- Lift the vacuum pump



CAUTION

The vacuum pump may not be lifted anymore when it has been filled with oil.

Moving of the vacuum pump is simple using the four wheels placed under the vacuum pump frame.

The design of the baseframe is such that transport of the pump can be made with a Europe pallet truck.

Make sure before every transport that the oil has been drained out of the vacuum pump.

The packaging material must be disposed of in accordance with local and national regulations.

This handbook is contained in the delivery package.

Storage

Temporary storage

- Make sure that the intake and exhaust flanges are closed (put on the protective caps included in the delivery package of the vacuum pump)
- Store the vacuum pump
 - if possible, the vacuum pump should be stored in its original packaging,
 - indoors,
 - dry,
 - in a dust-free and
 - vibration-free room

Removal of the pump

Before starting a vacuum pump that has been stored outside the building for a while, the vacuum pump must be moved to a room with ambient temperature, where it should rest for a day.

Preservation

If the vacuum pump will be exposed to unfavourable ambient conditions (for example, aggressive environment, frequent temperature changes), begin immediately with preservation work on the vacuum pump.

In the case of favourable ambient conditions, perform preservation work on the vacuum pump if a storage period of more than three months is planned.

- Make sure that all openings are hermetically sealed; use adhesive tape to fasten loose parts (seal rings, flat seals, etc.).

NOTE: VCI is the abbreviation for "volatile corrosion inhibitor". The VCI molecule is an organic corrosion inhibitor in the vapour phase. Integrated in various carriers such as film, cardboard, paper, foam, liquid and powder, it protects the parts against corrosion as a result of its action in the vapour phase. However, VCI packaging can attack synthetic surfaces and surfaces of other elastomers. If in doubt, please contact your nearest distributor. VCI packaging provides several years of protection against corrosion, even under the harshest of conditions: overseas shipment, extended storage before use.

- Wrap the vacuum pump in a VCI film
- Store the vacuum pump
 - if possible, the vacuum pump should be stored in its original packaging,
 - indoors,
 - dry,
 - in a dust-free and
 - vibration-free room

Start-up of the vacuum pump after storage:

- Make sure that all protective elements, stoppers or adhesive tapes attached before preservation have been removed
- Switch on the vacuum pump in the sequence described in the chapter "Installation and start-up"

Installation and start-up

Necessary installation instructions



CAUTION

If the necessary installation instructions are not followed and particularly in the case of inadequate cooling:

Risk of damage to and total destruction of the vacuum pump and its components!

Risk of personal injury!

The necessary installation instructions must be followed.

- Make sure that the integration of the vacuum pump in its new environment complies with the safety regulations according to the Machinery Directive 2006/ 42/ EC (regarding the responsibility of the manufacturer of the system in which the vacuum pump is to be integrated, see information in the Declaration of Conformity).



WARNING

Local regulations regarding the motors and electric control elements must be observed when installing the pump in potentially explosive environments. Make sure before start-up that all safety measures have been followed.

Installation site and installation

- Make sure that the environment of the vacuum pump is not potentially explosive
- Make sure that the following ambient conditions are fulfilled:
 - Ambient temperature: 0 ... 40 °C (32 ... 104 °F)
 - Ambient pressure: atmosphere
 - Humidity range: 20 to 95%
 - Altitude: up to 1000 m



CAUTION

In case of high ambient temperature, extract the air between the machine panel and pumps casings by connecting on ventilating extractor to the casing vent of min. 30 m³/h.

Do not connect the ventilating extractor with any process gas discharge.

- Make sure that the cooling water fulfills the following requirements:
 - Temperature: 10 - 20 °C
 - Overpressure: 4 bar (relative)
 - Approximate flow rate: 1 l/ min for the standard version
 - Water hardness: < 5° dGH

NOTE: 1° (german degree = 1° dGH) = 1,78° (french degree) = 1,25 e (english degree) = 17,9 mg/kg CaCO₃ (american hardness)

- Make sure that the cooling water is neutral and clean
- Make sure that the cooling water outlet is unpressurised
- Make sure that the nitrogen fulfills the following requirements:
 - Overpressure: 4,0 bar
 - Approximate flow rate: 25 (CDA) l/ min
- Make sure that the ambient conditions correspond to the protection class of the motor (according to nameplate)
- Make sure that the vacuum pump is placed on or fastened to a horizontal surface
- Make sure that the vacuum pump is level

NOTE: The levelling of the pump is facilitated by the adjustment stroke (~15 mm) of the four machine feet.

- Make sure that the four rollers do not touch the ground

NOTE: In order to ensure the fixation of the pump to the ground, it is possible to use again the four yellow brackets that were removed at the reception of the machine.

- Make sure that the vacuum pump is at least 1 m away from any wall to ensure good cooling
- Make sure that the vacuum pump is easily accessible and that the selected installation site fulfills the requirements for assembly/dismantling
- Make sure that no temperature-sensitive parts (for example, of plastic, wood, cardboard, paper, electronic parts) come into contact with the hot surfaces of the vacuum pump
- Make sure that the installation site or assembly area is ventilated in such a way that adequate cooling of the vacuum pump is ensured



CAUTION

The surface temperature of the vacuum pump can exceed 50°C when the vacuum pump is in operation.

Danger of burns!

- Make sure that no-one can touch the vacuum pump accidentally. If necessary, attach safeguard
- Make sure that the oil sight glasses (OSG) are easily accessible

If oil changes are to be made on site:

- ◆ Make sure that the oil drain and oil filler are easily accessible

Inlet connection

- Make sure that the protection that was attached to prevent penetration of particles during transport has been removed before the vacuum pump is connected to the vacuum line



CAUTION

Do not put hands into the inlet aperture.

Risk of body damage!



CAUTION

The intake of liquids or solid particles can lead to the destruction of the vacuum pump

If the sucked gas contains dusts or solid foreign bodies:

- ◆ Make sure that a filter or protective grating is installed at the extraction point
- Make sure that the nominal diameter of the intake line is at least equal to the diameter of the intake flange of the vacuum pump to prevent a drop in the performance of the vacuum pump in the case of a smaller cross-section
- Make sure that the vacuum pump is connected with leakproof lines



CAUTION

When the intake lines have been connected, make sure that the system does not leak. Leakages of dangerous substances must be prevented!

- Make sure that the intake lines are equipped with a shut-off device upstream of the intake flange so that the flow of sucked gas can be stopped
- Make sure that the intake lines do not exercise any force on the intake flange. Mount bellows if necessary
- The inlet flange has the following dimension:

- DN 50 ISO KF

In the case of long intake lines the line cross-section should be larger than the intake flange to prevent a drop in the performance of the vacuum pump. If you have any doubts, contact your Busch representative.

Discharge connection



CAUTION

Do not put hands into the outlet aperture.

Risk of body damage!

The following instructions for connection to the discharge only apply if the sucked gas is discharged by the vacuum pump into a suitable environment.

- Make sure that the protection that was attached to prevent penetration of particles during transport has been removed before the vacuum pump is connected to the vacuum line
- Make sure that the nominal diameter of the exhaust line is at least equal to the diameter of the exhaust flange of the vacuum pump to prevent a drop in the performance of the vacuum pump in the case of a smaller cross-section
- Make sure that the vacuum pump is connected with leakproof lines



CAUTION

When the discharge lines have been connected, make sure that the system does not leak. Leakages of dangerous substances must be prevented!

- Make sure that the discharge line is mounted in such a way that condensate cannot penetrate into the pump (siphon trap, gradient)
- Make sure that no shut-off devices are mounted in the discharge line
- Make sure that the discharge lines do not exercise any force on the discharge flange. Mount bellows if necessary
- The discharge flange has the following dimension:

- DN 40 ISO KF

In the case of long discharge lines the line cross-section should be larger than the discharge flange to prevent a drop in the performance of the vacuum pump. If you have any doubts, contact your Busch representative.

Cooling water connection

The cooling water is generally connected with a hose.

The cooling water outlet must be unpressurised.

Connection diameter: 3/8 NPT

Nitrogen connection

The nitrogen is connected with a pipe (leakproof against oxygen).

Connection diameter: 1/4 NPT

Electrical connection/ Checks

- Make sure that the regulations of the Electromagnetic Compatibility Directive 2014/30/EU as well as standard EN norms, safety directives and especially local and national regulations are observed (this is the responsibility of the manufacturer of the system into which the vacuum pump is integrated according to the Declaration of Conformity)
- Make sure that the mains power supply corresponds to the data on the nameplate of the motor
- Make sure that an overload cut-out according to EN 60204-1 is provided for the motor

- Make sure that the drive of the vacuum pump is not disturbed by any electric or electromagnetic interferences. If you have any doubts, contact your Busch representative

Power wiring connections

Power wiring connection	
1(A)	Phase L1
2(B)	Phase L2
3(C)	Phase L3
4(D)	Ground

Power connector on vacuum pump front side

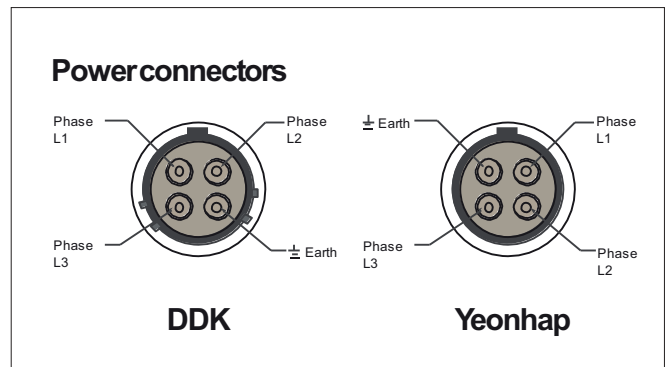

Installation

Mounting

- Make sure that the "Necessary installation instructions" are followed
- Fasten or install the pump at its final installation site

Electrical connection



WARNING

Risk of electrocution, risk of damage.

Electrical installation must be performed by a suitably qualified electrician who knows and follows the following regulations:

- IEC 364 or CENELEC HD 384 or DIN VDE 0100,
- IEC Report 664 or DIN VDE 0110,
- VBG 4 or corresponding national regulations on accident prevention



CAUTION

The circuit diagrams described below conform to the standard. Other circuit diagrams might be used. This depends on the particular order and the market.

Risk of damage to the motor!

Check the connection of the motor inside the terminal box according to the circuit diagram.

Motor of screw pump COBRA BC 0100 F PE is connected at factory.

- Connect supply cable on the female connection (EC) of the vacuum pump



CAUTION

The transformer voltage (in the electrical box) must be in accordance with the supply voltage of the machine.



CAUTION

If the vacuum pump is operated with a motor that turns in the wrong direction, it can be destroyed, even if this is the case for only a short moment.

Make sure that the vacuum pump is connected correctly before switching it on.

- Determine rotation sense of the motor by placing a rubber plate on the inlet.
- Press the on/ off switch briefly
- Make sure that the vacuum pump sucks

If the direction of rotation has to be changed:

- ◆ Exchange two of the three feeder leads

Equipment connections (with options)

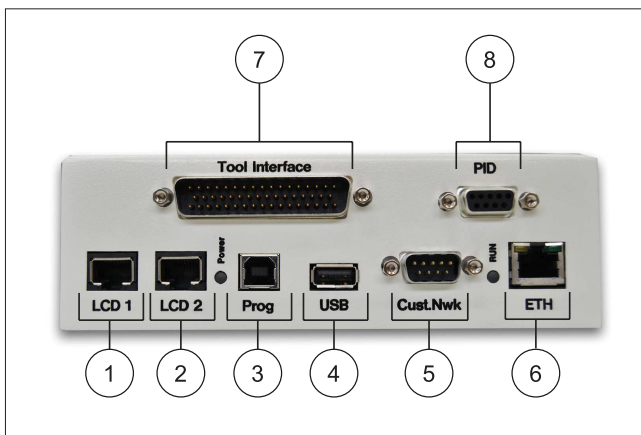

- 1 LCD serial wiring (RJ45), LCD 1
- 2 LCD serial wiring (RJ45), LCD 2
- 3 PC serial wiring (9 poles) (option)
- 4 USB connection
- 5 Customer Network, Communication modbus RTU RS 232
- 6 Ethernet Network connection (Busch Monitoring System) (option)
- 7 Interface connection (50 poles) (option)
- 8 PID Interface (9 poles) (option)

The information concerning the use of the Busch PLC and the Busch LCD can be found in the Operation and Maintenance Instructions (Art-No. 0870758077).

Connection of the lines/ pipes

- Connect the intake lines
- Connect the discharge lines
- Make sure that all caps, safeguards and similar covers are mounted
- Make sure that the inlet and outlet for the cooling air are not covered or closed and that the flow of cooling air is not impaired in any way

Oil filling

The COBRA BC 0100 F PE vacuum pumps are always delivered without oil (see the chapter "Oil types" for information on the recommended oils).

- Prepare the quantity of oil specified in the table "Oil quantity"

Oil filling	BC 0100 F PE	Oil type
Oil capacity [Liter]	0,12	Busch YLC 250 B, Art. No. 0831 131 400

NOTE: The quantity of oil specified in the installation handbook is of informative nature only. Check the oil level with the help of the oil sight glass (OSG) on the vacuum pump.



CAUTION

Before you change the type of oil, make sure that the new type is compatible with the old type. If necessary, flush the vacuum pump.

- Unscrew the oil fill plug (OFF)
- Fill in oil

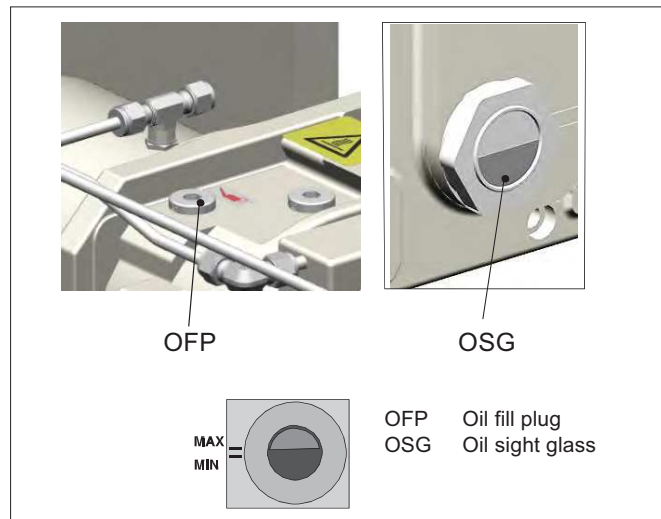

- Make sure that the oil level lies between the MIN and MAX markings on the oil sight glass
- Make sure that the seal of the oil filler cap is not damaged. Replace it if necessary
- Screw on the oil filler cap hermetically tight

NOTE: It is easier to switch on the vacuum pump with cold oil when the intake line is not closed or when the intake flange is not covered by a rubber plate.

- Start the vacuum pump

If the intake line is equipped with a shut-off device:

- ◆ Close the shut-off device

If the intake line is not equipped with a shut-off device:

- ◆ Place a rubber plate on the intake flange
- Let the vacuum pump run for a few minutes
- Stop the vacuum pump and wait a few minutes
- Make sure that the oil level still lies between the MIN and MAX markings on the oil sight glass

If the oil level is below the MIN marking:

- ◆ Fill in more oil

If the intake line is equipped with a shut-off device:

- ◆ Open the shut-off device

If the intake line is not equipped with a shut-off device:

- ◆ Remove the rubber plate from the intake flange and connect the intake line to the intake flange



CAUTION

The vacuum pump may not be lifted anymore when it has been filled with oil.

- Make sure before every transport that the oil has been drained out of the vacuum pump.



CAUTION

The vacuum pump must remain in a horizontal position when it has been filled with oil.

Checking the direct cooling

The flow of the cooling water is checked by the flowmeter CWM. The flowmeter must be connected in such a way that switching-on leads to an alarm and stopping of the vacuum pump when the flow drops below 0,3 l/min.

Saving the operating parameters

As soon as the vacuum pump is working under normal conditions after being switched on:

- Measure the working current of the motor and save it as reference value for all future maintenance and repair work

Recommendations on operation

Application



WARNING

The vacuum pump is designed for use under the conditions specified here.

If these conditions are not met, there is a risk of damage to or total destruction of the vacuum pump and its components!

The vacuum pump may only be switched on under the specified conditions.

The COBRA BC vacuum pumps are designed for use in the field of microelectronics and similar industries.

They can be used to suck gases and gas mixtures.



WARNING

When using toxic, inflammable and/ or explosive gases, make sure that the system corresponds in design to applicable local and national safety regulations and that all applicable safety measures are followed. All product-specific safety regulations must be observed.

Solid particles must not get into the vacuum pump. Procedural errors can result in the pump sucking in a certain quantity of liquid. If the pump has sucked in liquid, a short drying time is necessary at the end of the procedure.

The allowed maximum inlet gas temperature depends on the inlet pressure and the type of gas: the lower the inlet pressure (Pa), the higher the drawn gas temperature (T_{Gas}) can be.

The following indicative values for air can be considered:

- Pa > 50 mbar, T_{Gas} < 80°C
- Pa < 50 mbar, T_{Gas} < 200°C

The vacuum pump is intended for use in a potentially non-explosive environment.

As far as temperature is concerned, the vacuum pump is suitable for evacuation of a 300 liters tank. The vacuum pump is not suitable for continuous duty at a pressure more or equal than 150 (hPa) mbar. Caution, the operating cycle of 150 (hPa) mbar must not exceed more than 5 min. For other applications, contact your Busch representative.

- Maximum inlet pressure: 1 bar (abs).
- With vacuum pump running at full speed, do not expose to inlet pressure > 300 (hPa) mbar.

The vacuum pump is tight down to ultimate pressure.



CAUTION

The surface temperature of the vacuum pump can exceed 50 °C when the vacuum pump is in operation.

Danger of burns!

The vacuum pump may not be touched when it is in operation. If touching the pump is unavoidable, wait until the surface temperature has cooled down or wear protective gloves.



CAUTION

The intensity of the noise of the vacuum pump is higher within a certain area of the pump.

Risk of hearing damage!

Users must wear ear protection when spending a longer period of time in the vicinity of a non-insulated vacuum pump.



CAUTION

The COBRA BC 0100 F PE vacuum pumps are always delivered without oil and without cooling water.

Operation without oil will result in damage to the vacuum pump!

The vacuum pump must remain in a horizontal position when it has been filled with oil.



CAUTION

The cooling water flow, which is checked by the flowmeter CWM, must be at least 1 l/min.

- Make sure that all caps, safeguards and similar covers are mounted
- Make sure that the safeguards are switched on
- Make sure that the inlet and outlet for the cooling air are not covered or closed and that the flow of cooling air is not impaired in any way
- Make sure that the system does not leak. Leakages of dangerous substances must be prevented
- Make sure that the "Necessary installation instructions" are followed and especially that adequate cooling is ensured

The following must be noted when the pump is shut down for a longer period of time:



CAUTION

If there is a risk of frost, all the cooling water must be drained out of the vacuum pump if the pump is shut down for a longer period of time!

- Drain the cooling water
 - ◆ Pull off the connections for the inlet and outlet of the cooling water

- ◆ Drain the cooling water completely
- ◆ If necessary, drain the cooling water with the help of compressed air to prevent any risk of frost or corrosion

Switching the vacuum pump on/off

First start-up of the system

- Make sure that the "Necessary installation instructions" are followed

If the system is equipped with a solenoid gate valve in the cooling water circuit:

- ◆ Open the solenoid gate valve
- Make sure that the cooling water flow is set correctly
- The cooling water flow is factory set on 1 l/min and can be adjusted at the regulating cock CWR. This water circuit is used to cool the motor of the NW pump and also the body of the pump.

- Switch on the vacuum pump
- Make sure that the system does not leak

If the system is equipped with a solenoid gate valve at the intake:

- ◆ Open the solenoid gate valve

Switching the system off

- Flush the vacuum pump with nitrogen at the end of the process (the duration of flushing can be programmed)

If the system is equipped with a solenoid gate valve at the intake:

- ◆ Close the solenoid gate valve
- Switch off the vacuum pump
- Shut off the nitrogen supply
- Shut off the cooling water supply

If the system is equipped with a solenoid gate valve in the cooling water circuit:

- ◆ Close the solenoid gate valve
- Make sure that the system is currentless

Maintenance



In case the vacuum pump has conveyed gases that have been contaminated with foreign materials that are dangerous to health, the oil and condensates will also be contaminated.

These foreign materials can infiltrate the pores, recesses and other internal spaces of the vacuum pump.

Danger to health when the vacuum pump is dismantled.

Danger to environment.

Always wear protective clothing when carrying out maintenance work.

Before any maintenance work, the inlet and outlet piping as well as the vacuum pump itself must be flushed with nitrogen.



Only authorised personnel may carry out dismantling work on the vacuum pump. Before work begins, the operator of the vacuum pump must fill in a form or a "Declaration Regarding Contamination of Equipment and Components" that provides information on possible dangers and appropriate measures. If this form has not been filled in completely and signed, the vacuum pump may not be dismantled.



Before maintenance work is started, a safety area of at least 610 [mm] around the machine must be set up.



The surface temperature of the vacuum pump can exceed 50°C when the vacuum pump is in operation.

Danger of burns!

Before starting maintenance work, make sure that the vacuum pump has been switched off and that it cannot be switched on again accidentally. Follow the shutdown procedure in the section "Lock Out/Tag Out procedure":

- stop the pump with the remote control (press on STOP button during 10s)
- press on emergency stop button
- switch off the main breaker
- switch off the customer's power supply
- switch off the water and nitrogen quick connections (inlet first, then outlet)
- put the label or warning board "Maintenance processing" on or next to the pump



The oil temperature can reach a value of 90°C!

Danger of burns!

- Make sure that the oil circuit and the coolant circuit have been emptied before moving the vacuum pump
- Make sure that there are no cleaning tools in the pump anymore according to local and national regulations

Before pulling off the different connections, make sure that the intake and exhaust lines of the vacuum pump correspond to atmospheric pressure

When the maintenance work has been finished, follow the procedure "Safety Lockout procedure":

- take off the label or warning board "Maintenance processing"
- check the oil level according to the chapter "Checking the oil level"
- switch on the main breaker
- release the emergency stop button
- switch on the water and nitrogen quick connections (outlet first, then inlet)
- make sure that the "Necessary installation instructions" are followed
- start the pump with the remote control (press on START button)

Maintenance program

NOTE: The maintenance intervals depend on the operating conditions. The following intervals are basic values, which can be shortened or lengthened depending on operating conditions. In especially difficult operating conditions such as, for example, a very dusty environment the maintenance intervals must be shortened considerably.

Weekly:

- Check the oil level and the colour of the oil (see "Checking the oil")
- Check the cooling water flow (see "Checking the cooling water")
- Check the nitrogen flow (see "Checking the nitrogen")
- Inspect the vacuum pump for oil leaks - if there are leaks, repair the vacuum pump (Busch)

- Inspect the vacuum pump for leaks of cooling water - if there are leaks, repair the vacuum pump (Busch)

Monthly:

In the case of operation in a dusty environment:

- ◆ Make sure that the operating room is clean and free of dust; clean if necessary
- Make sure that the vacuum pump has been switched off and that it cannot be switched on again accidentally
- Check the electrical connections
- Carry out a visual inspection of the vacuum pump

Yearly:

- Make sure that the vacuum pump has been switched off and that it cannot be switched on again accidentally

If the intake is equipped with a sieve:

- ◆ Check the sieve at the intake and clean if necessary
- Check the measuring and safety equipment for working order

If the discharge is equipped with a sound absorber:

- ◆ Clean the sound absorber

If the discharge is equipped with a leak-protection non-return valve:

- ◆ Clean the leak-protection non-return valve
- Drain the oil (see "Draining the oil")

If the cooling water line is equipped with a filter:

- ◆ Check the filter and clean or replace if necessary
- Check the seals and replace if necessary
- Check the intake and discharge lines and clean or replace if necessary

Every 16 000 hours of operation, at the latest after 4 years:

- Drain the oil (see "Draining the oil")
- A main inspection of the vacuum pump (Busch)

Lock Out/ Tag Out procedure

- Stop the pump with the remote control (press on STOP button during 10s)
- Press on emergency stop button
- Switch off the main breaker
- Switch off the customer's power supply
- Switch off the water and nitrogen quick connections (inlet first, then outlet)
- Put the label or warning board "Maintenance processing" on or next to the pump

Safety Lockout procedure

- Take off the label or warning board "Maintenance processing"
- Check the oil level according to the chapter "Checking the oil level"
- Switch on the main breaker
- Release the emergency stop button
- Switch on the water and nitrogen quick connections (outlet first, then inlet)
- Make sure that the "Necessary installation instructions" are followed
- Start the pump with the remote control (press on START button)

Checking the oil

Checking the oil level

- Make sure that the vacuum pump has been switched off and that it cannot be switched on again accidentally
- Indication of the oil level on the oil sight glass

If the oil level does not reach the MIN marking:

- ◆ Top up with oil (see "Refilling oil")

If the oil level exceeds the MAX marking:

- ◆ Check the condensate drain
- Drain the oil (see "Draining the oil")

Refilling oil

NOTE: Oil does not normally have to be refilled outside the recommended oil change intervals. A drop in the oil level indicates a fault (see "Troubleshooting").



CAUTION

Only fill in oil through the oil filler opening.



CAUTION

Danger of burns when the oil fill plug is open.

Danger of injuries when the oil fill plug is not screwed on properly.

Only unscrew the oil fill plug when the vacuum pump has been switched off.

The vacuum pump may only be switched on when the oil fill plug is properly closed and tight.

- Make sure that the vacuum pump has been switched off and that it cannot be switched on again accidentally
- Unscrew the oil fill plug (OFP)
- Fill in oil up to the middle of the oil sight glass
- Make sure that the oil level lies between the MIN and MAX markings on the oil sight glass
- Make sure that the seal of the filler cap is not damaged and that they sit properly. Replace it if necessary
- Screw on the fill plug again

Checking the colour of the oil

NOTE: The oil must be clear and transparent. A permanent milky colour is an indication for contamination by foreign bodies. A dark colour is an indication for oil that has been chemically altered or contaminated by foreign bodies.



WARNING

Dark colored oil may indicate a hazardous pump condition which could cause personal injury.



If dark oil similar to the example shown is observed, you have to contact the Busch Customer Service without delay.

Oil change



If the vacuum pump has pumped gases that were contaminated with foreign bodies that are hazardous to health, the oil is also contaminated with these foreign bodies.

There is a health hazard when changing contaminated oil.

There is also a danger to the environment.

Wear protective clothing when replacing contaminated oil.

Contaminated oil must be treated specially and must be disposed of according to applicable regulations.

Draining used oil

NOTE: After switching off the vacuum pump at normal operating temperature wait no more than 20 minutes before oil is drained.

- Make sure that the vacuum pump has been switched off and that it cannot be switched on again accidentally
- Make sure that the vacuum pump is vented to atmospheric pressure
- Put a drain tray underneath the oil drain plug
- Unscrew the oil drain plug
- Drain the oil

When the oil flow has stopped:

- ◆ Refit the oil drain plug
- Switch on the vacuum pump for a few seconds
- Make sure that the vacuum pump is switched off and cannot accidentally be switched on again
- Remove the oil drain plug again and drain any remaining oil
- Carefully unscrew and remove the magnetic plug
- Check that no metal swarf sticks to the magnet of the magnetic plug, clean if necessary
- Make sure that the sealing washer of the magnetic plug is not damaged, replace it if necessary
- Refit the magnetic plug and tighten up
- Make sure that the sealing washer on the drain plug is undamaged and correctly positioned, replace it if necessary
- Refit the oil drain plug and tighten up

Dispose of the used oil in compliance with applicable regulations



Because of wear and tear of the seal, it is recommended to replace the drain plug whenever the oil is changed.

Filling in new oil

- Prepare the quantity of oil needed (see "Oil type/quantity")



The use of chemically contaminated or polluted oil can lead to hazardous pump conditions which could cause personal injury.

NOTE: The quantity of oil specified in the installation handbook is of informative nature only. Check the oil level with the help of the oil sight glass on the vacuum pump.

- Make sure that the drain plug has been fitted properly and that they do not leak



Only fill in oil through the oil filler opening.

- Unscrew the oil fill plug (OFF)
- Fill in oil up to the middle of the oil sight glass
- Make sure that the oil level lies between the MIN and MAX markings on the oil sight glass
- Make sure that the seal of the fill plug is not damaged and that it sits properly. Replace it if necessary
- Screw on the fill plug again

Checking the cooling water

Checking the cooling water flow

- Check the cooling water flow regularly

If the flow drops, check for leaks

- ◆ Make sure that the specifications of the cooling water are followed

Checking the nitrogen

Checking the nitrogen flow

- Check the nitrogen flow regularly

If the flow drops, check for leaks

- ◆ Make sure that the specifications of the nitrogen are followed

Checking the current consumption

- Check the current intensity of the motor

An increased intensity is an indication for a fault (see "Troubleshooting")

Checking the sound absorber (accessory)

- Make sure that the condensate does not collect at the exhaust of the vacuum pump
- Drain the condensate at the drain opening and collect it in a container
- Dispose of the condensate according to applicable environmental protection regulations
- Check the sound absorber regularly and clean it if necessary

Checking the leak-protection non-return valve (accessory)

- Check the leak-protection non-return valve regularly and clean it if necessary



Wear protective clothing when carrying out maintenance work on the sound absorber and leak-protection non-return valve.

There could still be residues of contamination.

Overhaul



CAUTION

Inappropriate maintenance work on the vacuum pump can damage the pump.

Danger of explosion!

If requirements are not met, the vacuum pump may not be switched on!

Should work exceed the dismantling work described in this handbook, it may only be carried out by authorised persons.



DANGER

If the vacuum pump has pumped gases that were contaminated with foreign bodies that are hazardous to health, the oil and condensate are also contaminated with these foreign bodies.

These foreign bodies can penetrate into pores, openings and other internal parts of the vacuum pump.

There is a health hazard when dismantling the vacuum pump.

There is also a danger to the environment.

Prior to shipping, the vacuum pump must imperatively be decontaminated and the degree of contamination must be documented in a declaration of decontamination ("Declaration of Decontamination"), which can be downloaded from www.buschvacuum.com.

Busch service will only accept vacuum pumps that come with a completely filled in and legally binding signed form.

Removal from service

Temporary removal from service

Before disconnecting the intake and exhaust lines and switching off the cooling water and nitrogen lines, make sure that the lines have adjusted to atmospheric pressure

Recommissioning

- Make sure that the various protective elements, stoppers or adhesive tapes have been removed
- Switch on the vacuum pump by following the procedure described in the chapter "Installation and start-up"

Dismantling and disposal



DANGER

If the vacuum pump has pumped gases that were contaminated with foreign bodies that are hazardous to health, the oil and condensate are also contaminated with these foreign bodies.

These foreign bodies can penetrate into pores, openings and other internal parts of the vacuum pump.

There is a health hazard when dismantling the vacuum pump.

There is also a danger to the environment.

Protective clothing must be worn when dismantling the vacuum pump.

Prior to shipping, the vacuum pump must imperatively be decontaminated and the degree of contamination must be documented in a declaration of decontamination ("Declaration of Decontamination"), which can be downloaded from www.buschvacuum.com.

Dispose of the used oil and condensate according to applicable environmental protection regulations.

When the product has reached the end of its lifetime:

- decontaminate the vacuum pump



CAUTION

Dismantling work must be carried out by authorised personnel. Before work begins, the operator of the vacuum pump must fill in a form or a "Declaration of Decontamination" that provides information on possible dangers and appropriate measures.

If this form has not been filled in completely and signed, the vacuum pump may not be dismantled.

- drain the oil
 - ◆ dispose of the oil according to local environmental protection regulations
- begin dismantling the vacuum pump



CAUTION

Wear protective clothing when carrying out dismantling work.

- ◆ dispose of the vacuum pump as scrap metal
- dispose of the individual parts of the machine according to local regulations

A lithium battery is present inside the PLC:

- eliminate the lithium battery according to local and national regulations in place, relating to environment

Oil type/ quantity

Oil type

- Make sure that the oil type corresponds to specification:
 - Busch YLC 250 B, Art. No. 0831 131 400 (0,5 l \cong 1 kg)



WARNING

The use of chemically contaminated or polluted oil can lead to hazardous pump conditions which could cause personal injury.

Oil quantity

The quantity of oil specified in the following table is of informative nature only. Check the oil level with the help of the oil sight glass on the vacuum pump.

Quantity [Liter]	Quantity [Liter]
BC 0100 F PE	0,12

Technical data

Technical data		BC 0100 F PE
Nominal suction capacity	m ³ /h (cfm)	115 (68)
Ultimate pressure	hPa(mbar)/ Torr	0,005/ 0,003
Nominal motor rating	kW	1,5
Power consumption at ultimate pressure/ Idle mode	kW	0,55/ 0,4
Nominal motor speed	min ⁻¹	3600
Noise level (EN ISO 2151)	dB(A)	<58
Ambient temperature	°C (°F)	0-40 (32-104)
Maximal counter pressure	Discharge bar	0,2
Cooling water requirement	l/ min	min. 1.0
Cooling water pressure	bar/ ΔP	2 ... 5
Cooling water temperature	°C	10 - 25
Nitrogen requirement	l/ min	25 (CDA)
Nitrogen overpressure	bar	4,0
Weight	approx. kg	120

EU Declaration of Conformity

This Declaration of Conformity and the CE-mark affixed to the nameplate are valid for the machine within the Busch scope of delivery. This Declaration of Conformity is issued under the sole responsibility of the manufacturer. When this machine is integrated into a superordinate machinery the manufacturer of the superordinate machinery (this can be the operating company, too) must conduct the conformity assessment process for the superordinate machine or plant, issue the Declaration of Conformity for it and affix the CE-mark.

The manufacturer

Busch Manufacturing Korea, Ltd.
189-51, Soicheon-ro, Majang-myun
Icheon-si, Gyunggi-do, 467-813
Republic of Korea

declares that the machine(s): **COBRA BC 0100 F PE**

fulfil(s) all the relevant provisions from European directives:

- 'Machinery' 2006/42/EC
- 'Electromagnetic Compatibility' 2014/30/EU
- 'RoHS' 2011/65/EU Restriction of the use of certain hazardous substances in electrical and electronic equipment (incl. all related applicable amendments)

and comply(-ies) with the following designated standards that have been used to fulfil those provisions:

Standard	Title of the Standard
EN ISO 12100 : 2010	Safety of machinery - Basic concepts, general principles of design
EN ISO 13857 : 2019	Safety of machinery - Safety distances to prevent hazard zones being reached by the upper and lower limbs
EN 1012-1 : 2010 EN 1012-2 : 1996 + A1 : 2009	Compressors and vacuum pumps - Safety requirements - Part 1 and Part 2
EN ISO 2151 : 2008	Acoustics - Noise test code for compressors and vacuum pumps - Engineering method (grade 2)
EN 60204-1 : 2018	Safety of machinery - Electrical equipment of machines - Part 1: General requirements
EN IEC 61000-6-2 : 2019	Electromagnetic compatibility (EMC) - Generic standards. Immunity for industrial environments
EN IEC 61000-6-4 : 2019	Electromagnetic compatibility (EMC) - Generic standards. Emission standard for industrial environments
EN ISO 13849-1 : 2015 ⁽¹⁾	Safety of machinery - Safety-related parts of control systems - Part 1: General principles for design

⁽¹⁾ In case control systems are integrated.

Legal person authorized to compile the technical file
and authorized representative in the EU
(if the manufacturer is not located in the EU):

Busch Dienste GmbH
Schauinslandstr. 1
DE-79689 Maulburg

Icheon-si, 14.05.2021



Seung-hwa Yoo, General Director

UK Declaration of Conformity

This Declaration of Conformity and the UKCA-mark affixed to the nameplate are valid for the machine within the Busch scope of delivery. This Declaration of Conformity is issued under the sole responsibility of the manufacturer. When this machine is integrated into a superordinate machinery the manufacturer of the superordinate machinery (this can be the operating company, too) must conduct the conformity assessment process for the superordinate machine or plant, issue the Declaration of Conformity for it and affix the UKCA-mark.

The manufacturer

Busch Manufacturing Korea, Ltd.
189-51, Soicheon-ro, Majang-myun
Icheon-si, Gyunggi-do, 467-813
Republic of Korea

declares that the machine(s): **COBRA BC 0100 F PE**

fulfil(s) all the relevant provisions from UK legislations:

- Supply of Machinery (Safety) Regulations 2008
- Electromagnetic Compatibility Regulations 2016
- Restriction of the use of certain hazardous substances in electrical and electronic equipment Regulations 2012

and comply(-ies) with the following designated standards that have been used to fulfil those provisions:

Standard	Title of the Standard
BS EN ISO 12100 : 2010	Safety of machinery. Basic concepts, general principles of design. Risk assessment and risk reduction.
BS EN ISO 13857 : 2019	Safety of machinery - Safety distances to prevent hazard zones being reached by the upper and lower limbs.
BS EN 1012-1 : 2010 BS EN 1012-2 : 1996 + A1 : 2009	Compressors and vacuum pumps. Safety requirements. Air compressors and vacuum pumps.
BS EN ISO 2151 : 2008	Acoustics - Noise test code for compressors and vacuum pumps - Engineering method (grade 2)
BS EN 60204-1 : 2018	Safety of machinery. Electrical equipment of machines. General requirements.
BS EN IEC 61000-6-2 : 2019	Electromagnetic compatibility (EMC) - Generic standards. Immunity standard for industrial environments.
BS EN IEC 61000-6-4 : 2019	Electromagnetic compatibility (EMC) - Generic standards. Emission standard for industrial environments.
BS EN ISO 13849-1 : 2015 ⁽¹⁾	Safety of machinery. Safety-related parts of control systems. General principles for design.

⁽¹⁾ In case control systems are integrated.

Legal person authorized to compile the technical file
and importer in the UK
(if the manufacturer is not located in the UK):

Busch (UK) Ltd
30 Hortonwood
Telford - UK

Icheon-si, 14.05.2021

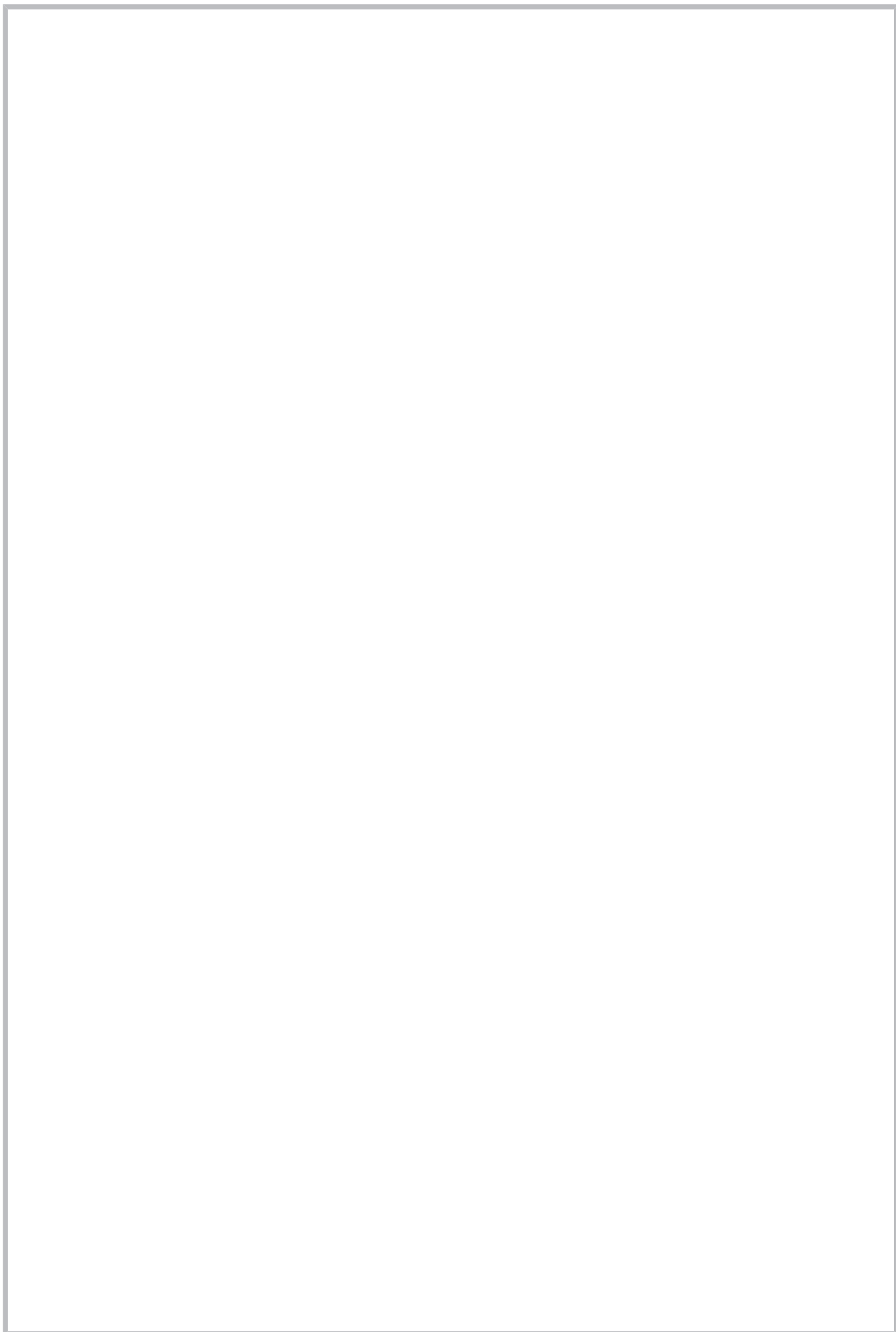

Seung-hwa Yoo, General Director

A large, empty rectangular box with a thin gray border, occupying most of the page. It is intended for writing a note.

Busch

Vacuum Solutions

We shape vacuum for you.

Argentina

info@busch.com.ar

Australia

sales@busch.com.au

Austria

busch@busch.at

Bangladesh

sales@busch.com.bd

Belgium

info@busch.be

Brazil

vendas@buschdobrasil.com.br

Canada

info@busch.ca

Chile

info@busch.cl

China

info@busch-china.com

Colombia

info@buschvacuum.co

Czech Republic

info@buschvacuum.cz

Denmark

info@busch.dk

Finland

info@busch.fi

France

busch@busch.fr

Germany

info@busch.de

Hungary

busch@buschvacuum.hu

India

sales@buschindia.com

Ireland

sales@busch.ie

Israel

service_sales@busch.co.il

Italy

info@busch.it

Japan

info@busch.co.jp

Korea

busch@busch.co.kr

Malaysia

busch@busch.com.my

Mexico

info@busch.com.mx

Netherlands

info@busch.nl

New Zealand

sales@busch.co.nz

Norway

post@busch.no

Peru

info@busch.com.pe

Poland

busch@busch.com.pl

Portugal

busch@busch.pt

Romania

office@buschromania.ro

Russia

info@busch.ru

Singapore

sales@busch.com.sg

South Africa

info@busch.co.za

Spain

contacto@buschiberica.es

Sweden

info@busch.se

Switzerland

info@buschag.ch

Taiwan

service@busch.com.tw

Thailand

info@busch.co.th

Turkey

vakutek@ttmail.com

United Arab Emirates

sales@busch.ae

United Kingdom

sales@busch.co.uk

USA

info@buschusa.com