

# DOLPHIN LB 0265-0425 A

Liquid ring vacuum pumps

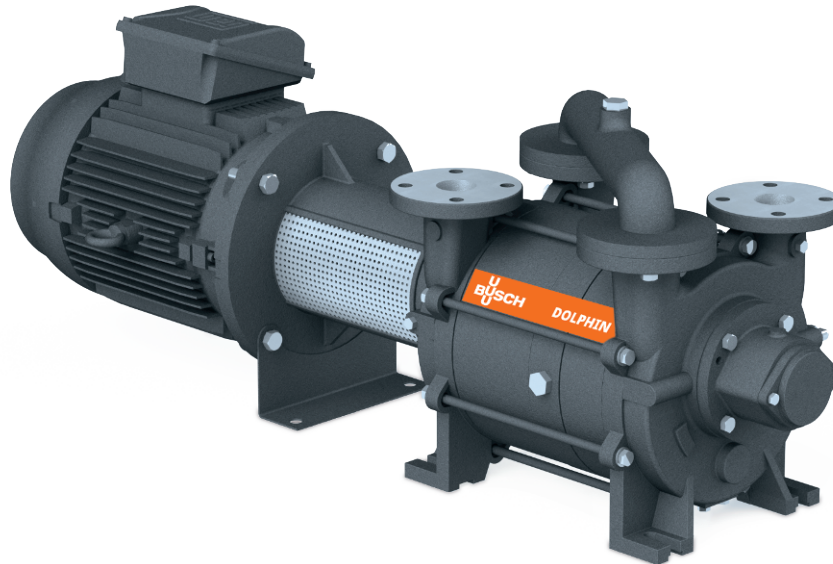

VACUUM SOLUTIONS



## Robust

Proven technology, durable two-stage construction

## Reliable

Extremely high vapor and particle tolerance

## Flexible

Wide range of construction materials, including cast iron (EN-GJL-200), many grades of stainless steel and even titanium, ATEX-certified version available (Cat 1(i)/2(o) IIC T5), operating fluids other than water possible, operation as compressor possible

Accessories, spare parts and options

- Partial or total recirculation systems
- Liquid separator
- Cavitation protection
- Heat exchanger
- Gas ejector
- Wide selection of motors
- Non-return valves
- Vacuum relief valves

# DOLPHIN LB 0265-0425 A

Liquid ring vacuum pumps



VACUUM SOLUTIONS

Dimensional drawing

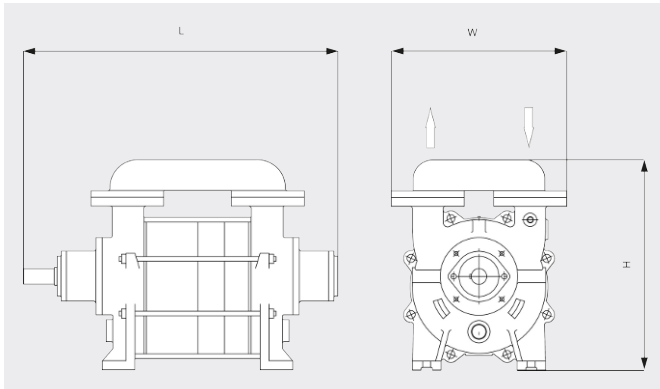

Pumping speed

Air at 20°C. Tolerance: ± 10%

— 50 Hz ..... 60 Hz

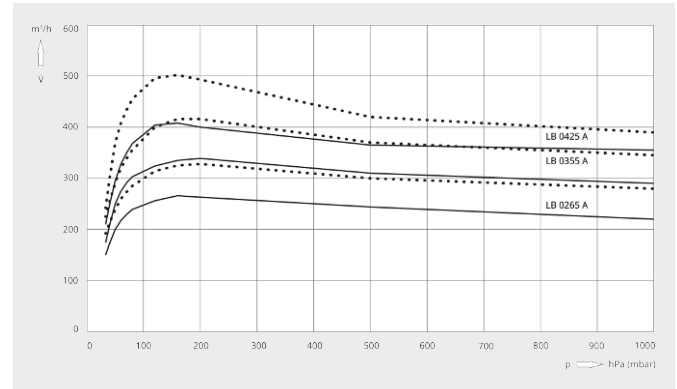

	DOLPHIN LB 0265 A	DOLPHIN LB 0355 A	DOLPHIN LB 0425 A
<b>Nominal pumping speed</b>	260 / 325 m³/h (50 / 60 Hz)	350 / 400 m³/h (50 / 60 Hz)	420 / 500 m³/h (50 / 60 Hz)
<b>Ultimate pressure</b>	33 hPa (mbar) (50 / 60 Hz)	33 hPa (mbar) (50 / 60 Hz)	33 hPa (mbar) (50 / 60 Hz)
<b>Nominal motor rating</b>	7.5 / 11 kW (50 / 60 Hz)	11 / 15 kW (50 / 60 Hz)	15 / 15 kW (50 / 60 Hz)
<b>Nominal motor speed</b>	1450 / 1750 min <sup>-1</sup> (50 / 60 Hz)	1450 / 1750 min <sup>-1</sup> (50 / 60 Hz)	1450 / 1750 min <sup>-1</sup> (50 / 60 Hz)
<b>Noise level (ISO 2151)</b>	75 dB(A) (50 / 60 Hz)	75 dB(A) (50 / 60 Hz)	75 dB(A) (50 / 60 Hz)
<b>Weight approx.</b>	165 kg	183 kg	194 kg
<b>Dimensions (L x W x H)</b>	( 707 – 898 ) x 300 x 472 mm	( 767 – 958 ) x 300 x 472 mm	( 807 – 998 ) x 300 x 472 mm
<b>Gas inlet / outlet</b>	DN 50 PN 10 / DN 50 PN 10	DN 50 PN 10 / DN 50 PN 10	DN 50 PN 10 / DN 50 PN 10

DO YOU WANT TO KNOW MORE?

Get in touch with us directly!



CONTACT FORM